

DuPont Fluoroproducts

DuPont Fluorochemical Emission Elimination Delivery (FEED) System

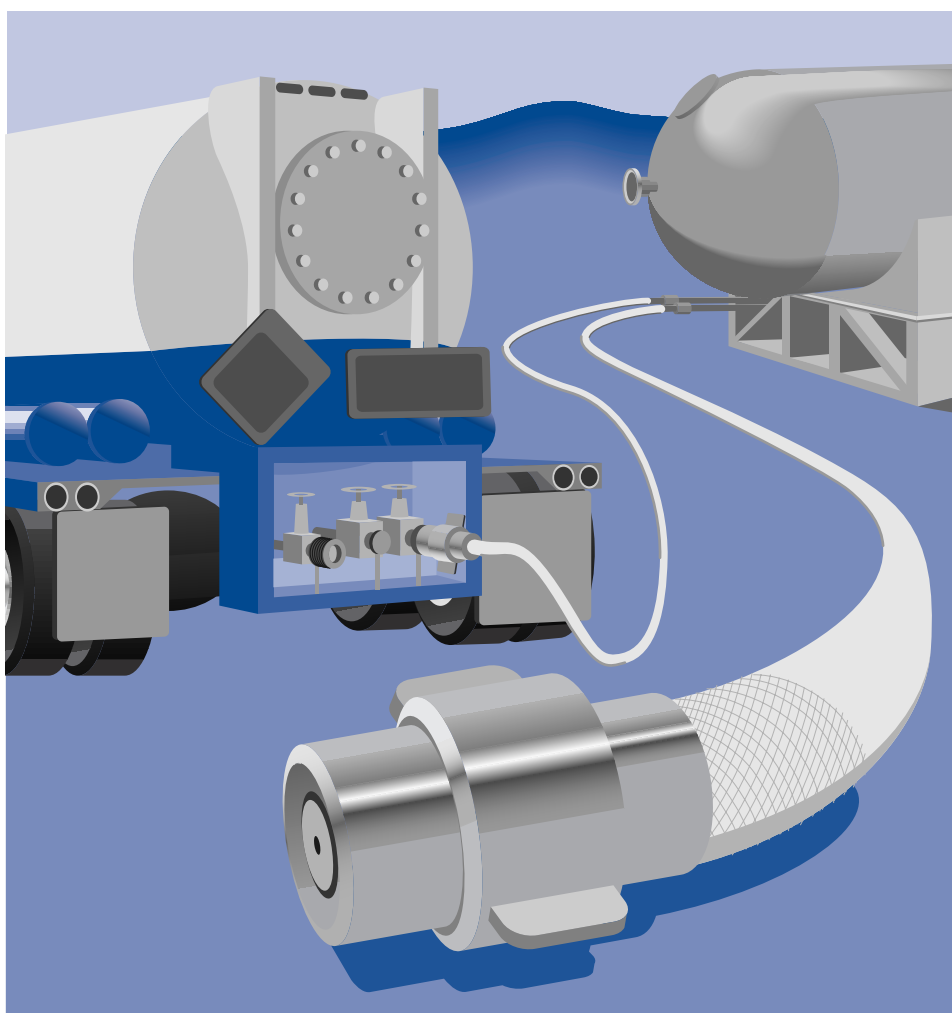

Introduction

The fluorochemical emission elimination delivery (FEED) system was developed to help eliminate CFC emissions associated with bulk deliveries. Prior to the FEED system concept, the fluorochemical left in the liquid delivery and vapor equalizing hoses was vented to the atmosphere before the Kamlok connections could be disconnected. The FEED system has the following differences:

- The Kamlok couplers are replaced by dry-disconnect couplers.
- There is a jumper with relief capability between the vapor line and the liquid fill line.
- Generally, the liquid and vapor delivery hoses are part of the customer's storage and handling system. *If there is a concern about having the hoses on site, DuPont can provide hoses on the delivery trailer.

To be environmentally responsible, DuPont decided to continue with the "zero-emission" delivery systems for the new nonozone-depleting product lines. This system has proven to be both cost-effective and reliable.

The FEED system costs approximately \$1200. Depending on the product price per pound, the customer will normally *recover this amount in 10 to 15 deliveries by not losing product to the atmosphere.*

* Not available for customers using flammable products, i.e., HFC-152a or dimethyl ether (DME).

Figure 1. No-Hose Delivery

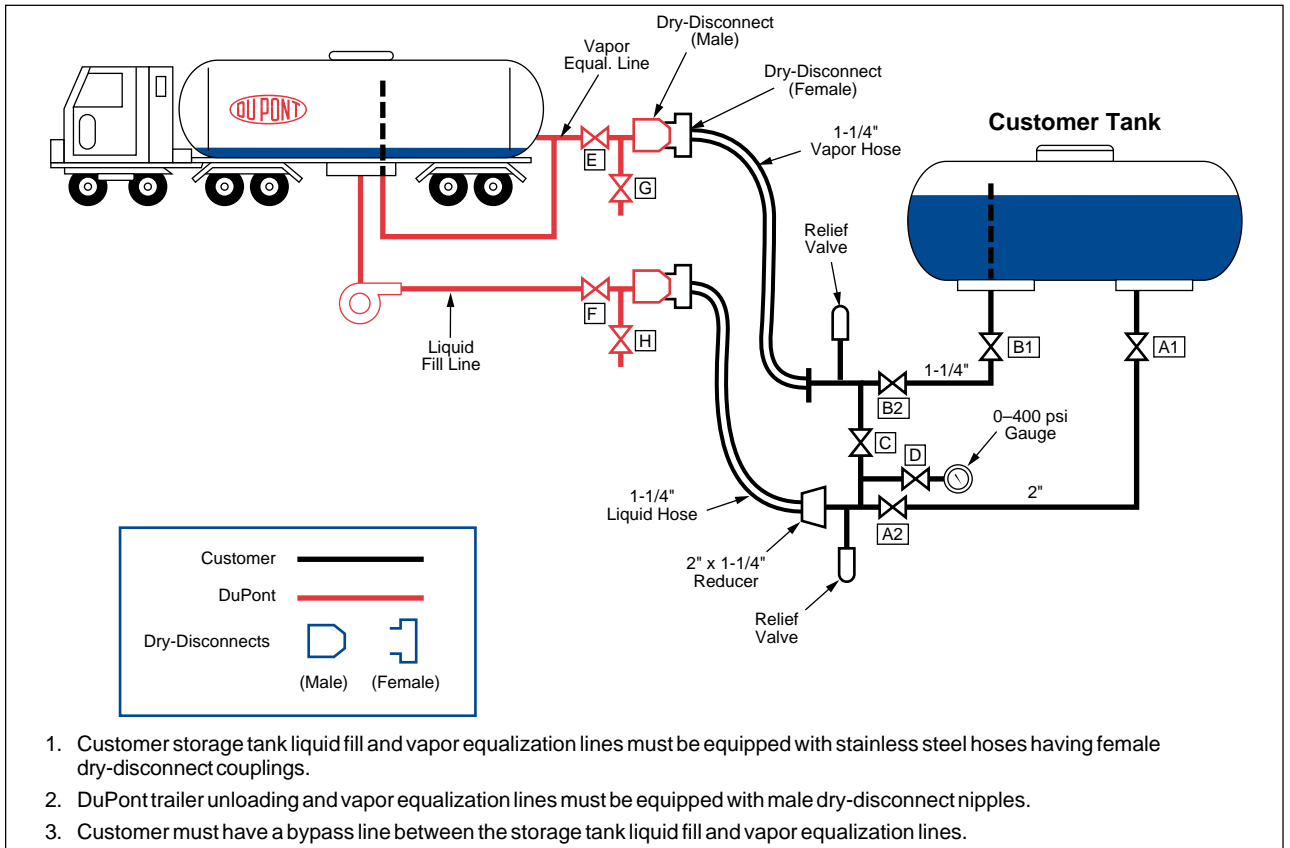

The current dry-disconnect design has been enhanced based on field experience. Working closely with DuPont Canada and DuPont Mexico, we are standardizing this unit for all bulk fluorochemical deliveries. This will provide substantial cost savings such as freight logical deliveries, flexibility, etc., as we eliminate the borders and operate as a single unit on this continent.

No-Hose Delivery Procedure Hose Connections

In most cases, DuPont trailers delivering fluorochemicals will not be equipped with hoses when delivering to customers equipped with a FEED system, *unless* hoses have been specified under "Special Instructions" on the order form. The following procedures are for customers who have hoses at their facility.

The liquid fill and vapor equalizing lines are each connected to stainless steel flexible 1-1/4" hoses with self-sealing couplings to connect to the delivery trailer. Dust covers are provided to protect the fittings from dust, dirt, and foreign matter. This system prevents product loss from emissions when hoses are disconnected. An equalizing line with pressure-relief valves is provided to prevent excessive pressure buildup in the hoses during storage by allowing liquid from the liquid fill hose/line to expand into the vapor equalization hose/line.

Operation of the self-sealing hose couplings is quick and convenient (see **Figure 1**).

1. Close the manual bypass valve on the equalizing line (C).
2. Remove the dust covers from the female dry-disconnects (customer's hoses) and the male dry-disconnects (DuPont trailer) *after* depressing the appropriate pressure-relief valve on each dust cover.
3. Thread the liquid fill and vapor equalization couplings to the appropriate trailer connections. Threads are timed to make the assembly seal before breaking valve seals.
4. Open customer liquid fill line valve (A2) and vapor equalization line valve (B2).
5. Open DuPont trailer liquid and vapor line valves (E and F).
6. Pump the product into the customer's tank using standard operating procedures.
7. After the delivery has been completed, turn the trailer pump off.
8. Close vapor and liquid valves on the DuPont trailer (E and F).
9. Close liquid and vapor valves on the customer's tank (A2 and B2).
10. Open the manual bypass valve on the equalizing line at the customer's tank (C).

11. Disconnect the liquid and vapor hoses from the trailer. Install dust covers on the couplings (hoses) and the nipples (trailer).
12. Store the hoses in the appropriate rack, tube, etc., provided by the customer.

*Hose Delivery Procedure

Hose Connections

While DuPont prefers to have liquid fill and vapor equalization hoses stored at the customer's facility, there will be a few customers who do not have hoses as part of their system. Therefore, DuPont has developed a simple and effective delivery concept whereby hoses are kept on the trailer.

The following procedure is to be followed by the driver/carrier after the unloading operation and before leaving the customer site. The customer storage tank and DuPont trailer must have the following features in place (see **Figure 2**):

1. The customer storage tank liquid fill and vapor equalization lines must be equipped with female dry-disconnect couplings.
2. The DuPont trailer unloading and vapor equalization lines must be equipped with male dry-disconnect nipples.

* Not available for customers using flammable products, i.e., HFC-152a or dimethyl ether (DME).

Figure 2. Hose Delivery

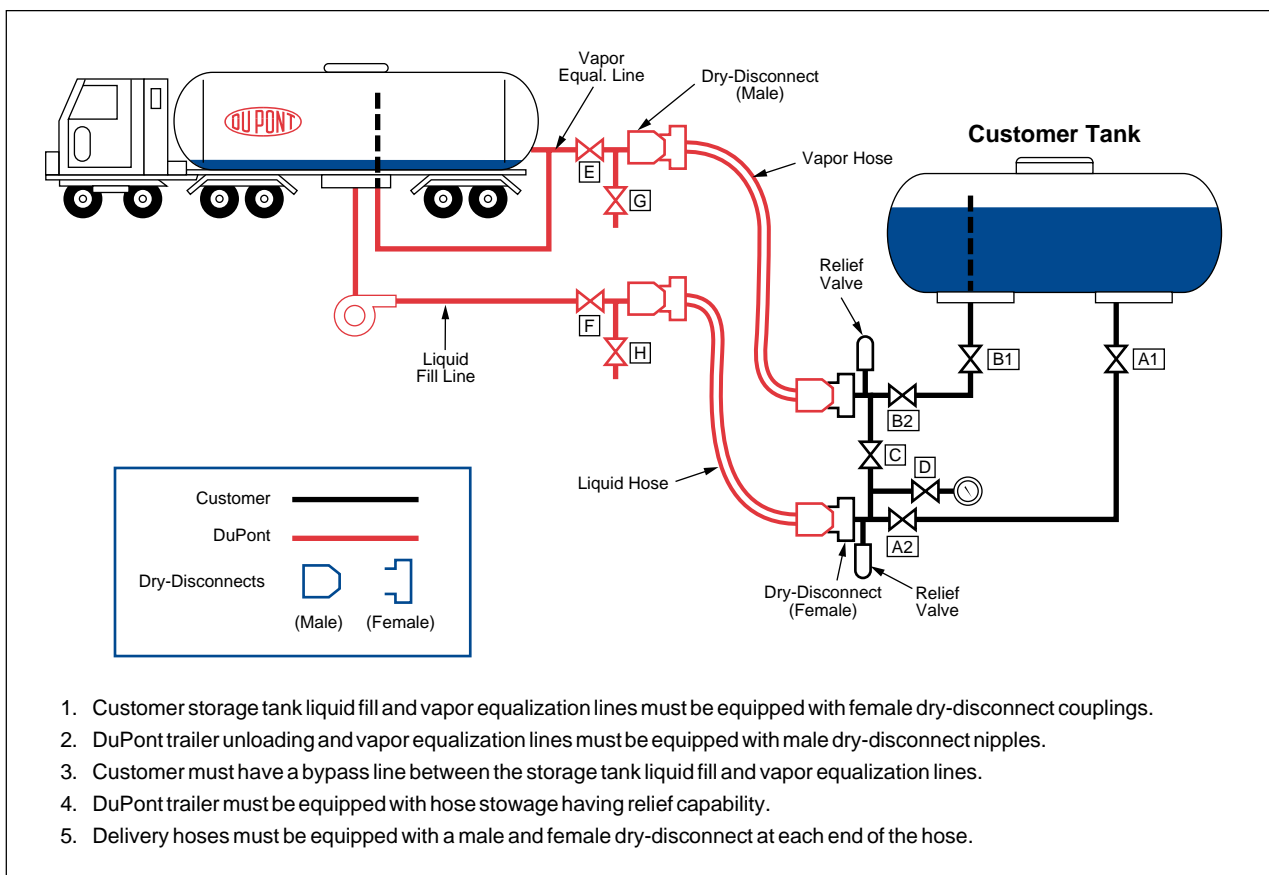

3. The customer must have a bypass line between the storage tank liquid fill and vapor equalization lines. This must be located after the tank shutoff valves and before the dry-disconnects and be equipped with a manual bypass valve with relief capability for both liquid and vapor lines.
4. The DuPont trailer must be equipped with hose stowage having relief capability.
5. The delivery hoses must be equipped with a male and female dry-disconnect at each end of the hose. Two hoses are usually required (one liquid fill, one vapor equalization). If additional hose is required, this *must* be indicated under “Special Instructions” on the order form.

Procedure

1. Turn trailer pump off after unloading is completed.
2. Close liquid and vapor valves on customer tank (A2 and B2).
3. Open liquid/vapor bypass valve (C).
4. Close vapor and liquid valves on DuPont trailer (E and F).
5. Disconnect liquid and vapor hoses from customer storage tank. Install dust plugs on female dry-disconnects on customer piping.
6. Disconnect liquid and vapor hoses from DuPont trailer. Install dust caps on male dry-disconnects on trailer.
7. Connect vapor and liquid hoses to each other at both ends. **Caution:** Be aware that liquid hose is full; use proper body position. Work with vapor hose—it is lighter in weight than liquid hose. (See **Figure 3.**)
8. Leave hoses connected for five minutes. Lift one end of hose to provide maximum equalization. In cold weather, allow extra time for equalization.
9. Detach liquid and vapor hoses at each end. Liquid and vapor hoses will each contain vapor/liquid material.

Figure 3. Hose Delivery

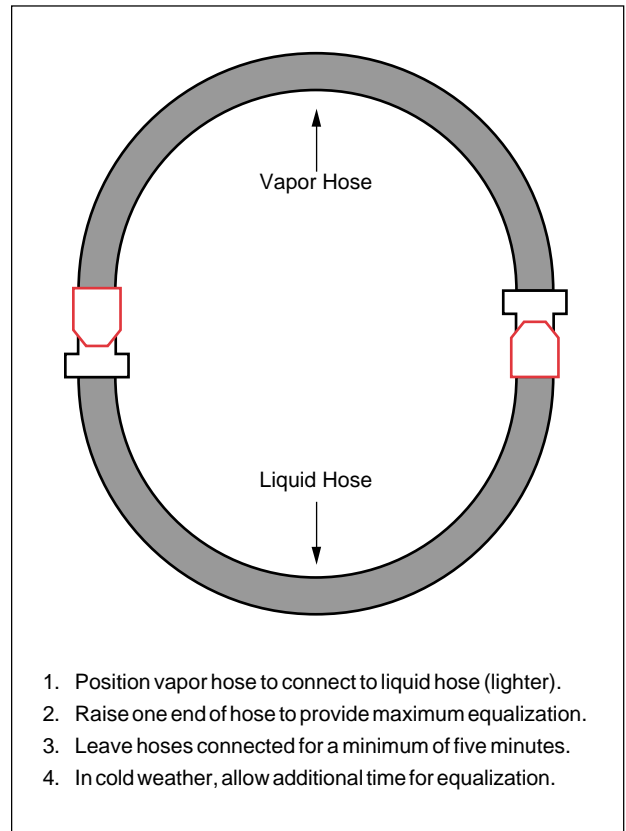

10. Install relief plugs on the female dry-disconnect of each hose. These relief devices are prefabricated on a male dry-disconnect. (See **Figure 4.**)
11. Install dust caps on the male dry-disconnect of each hose.
12. Store the hoses in the trailer stowage compartment, relief end facing towards front of trailer. This compartment is designed to relieve up to one gallon of liquid spillage.
13. Upon arrival at the DuPont facility, the hoses should be stored in containers having the proper relief capability at the designated plant storage area.

Figure 4. Hose Delivery

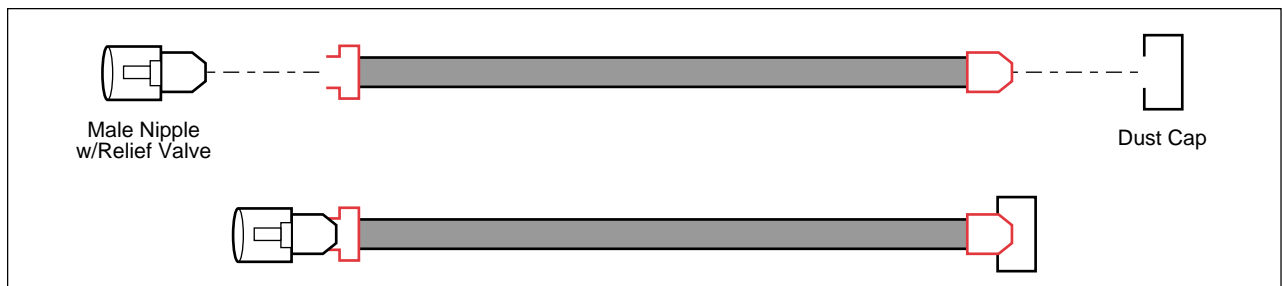
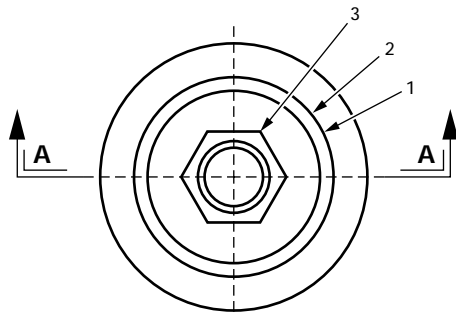
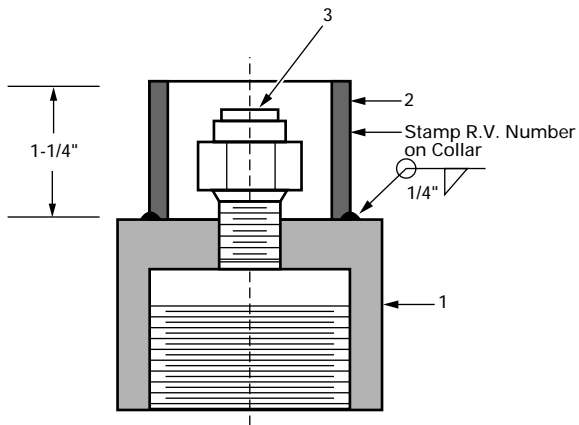

Figure 5. Relief Plug Design



PLAN



SECTION A-A

MATERIAL		
ITEM	DESCRIPTION	QTY.
1	1-1/2" Cap 3M TH FS A105 (Drill Thru and Tap for 1/4" MPT)	1
2	1-1/2" Pipe S40 CS SML A106-B BLK	1
3	1/4" R.V. Superior # 959BX5-E-375	1

TRAILER LOADING HOSE RELIEF VALVE DETAIL
SCALE: FULL SIZE

Figure 6. Hose Container Vent Design

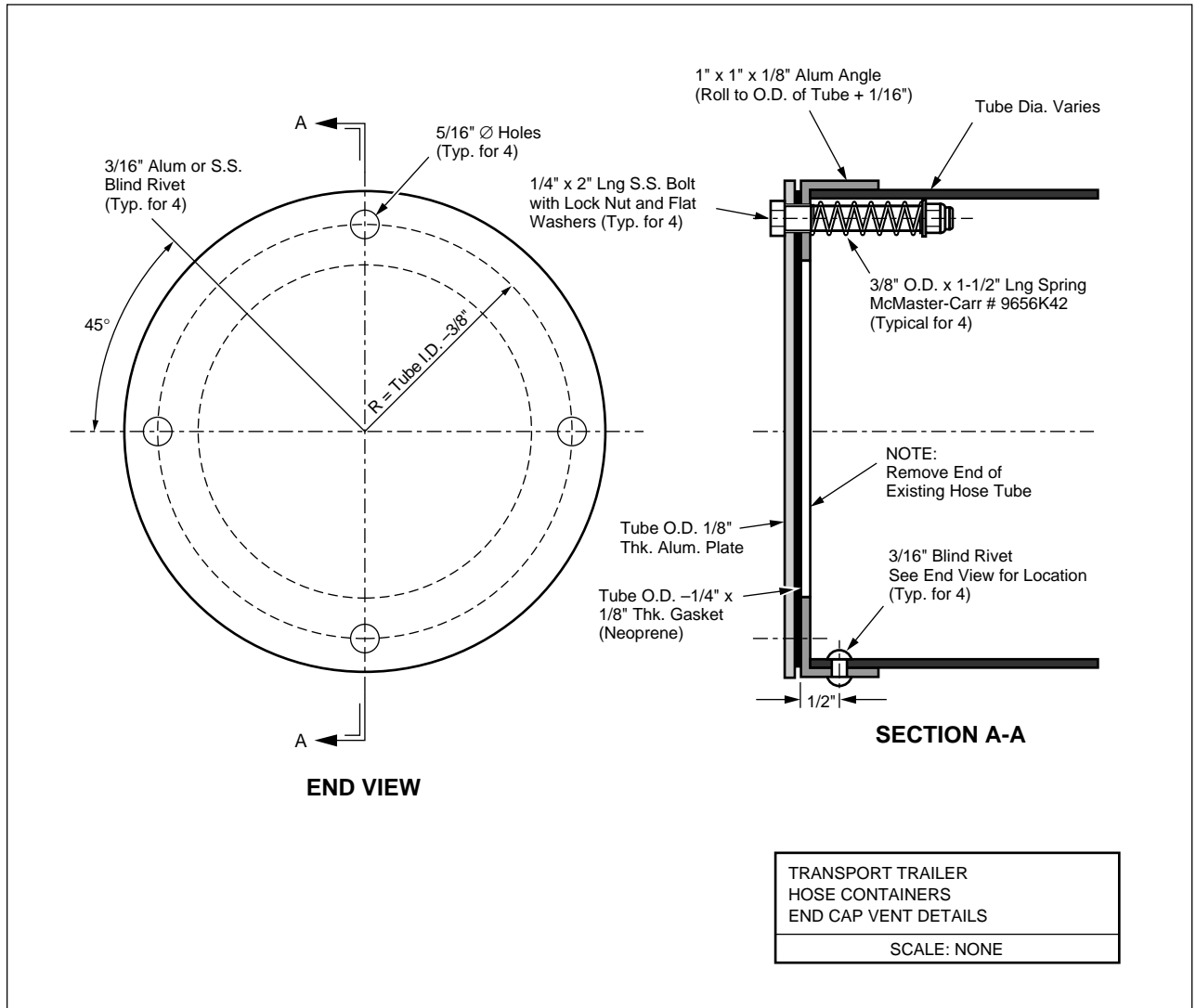

Parts/Installation

To purchase the DuPont FEED system, contact:

PSP Corporation
203 Churchill Drive
Wilmington, DE 19803-4203
(302) 764-2323

Part Numbers

Coupler (female) dry-disconnect: CP00110P1G1B

Dust plug: CP00110P3G1B

Installation Instructions

See **Figure 7**.

1. Ensure that valves A2 and B2 are closed (liquid and vapor line valves next to Kamlok couplings).
2. Open drain valves C and D and vent pressure between the valve and the Kamlok fittings on the liquid and vapor lines.

3. Remove the 2" and 1-1/4" Kamlok fittings.
4. Remove bleed valves C and D (save for next step).
5. Install 1/2" piping, relief valves, pressure gauge, and valves C and D for the equalizing line between the liquid and vapor piping (prevents excessive pressure buildup in the liquid line). See **Figures 8 and 9**.
6. Attach the dry-disconnect couplers (female) to the stainless steel hoses. Attach the hoses to the liquid and vapor piping, using a 2000 psi 2" x 1-1/4" reducing coupling with a 1-1/4" pipe nipple on the liquid line. Use Felpro "Tight" pipe dope on all threaded connections.

Note: Customers already using the DuPont CFC-12 FEED system only need to purchase the new dry-disconnect female couplings with dust caps. The CFC-12 disconnects (yellow dichromate-coated steel) should be removed and the new dry-disconnects (black-coated aluminum/steel) installed.

Figure 7. Typical Bulk Tank Without FEED System

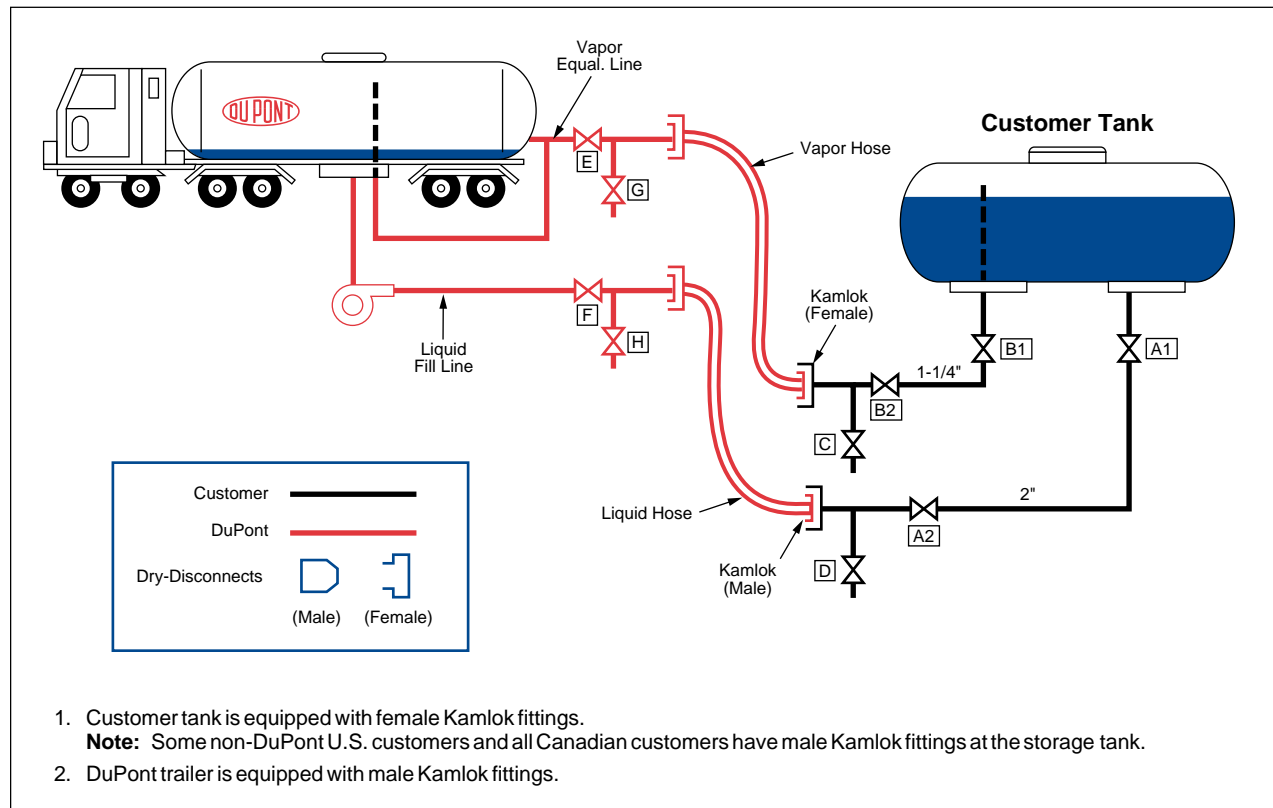

Figure 8. Typical Bulk Tank with FEED System

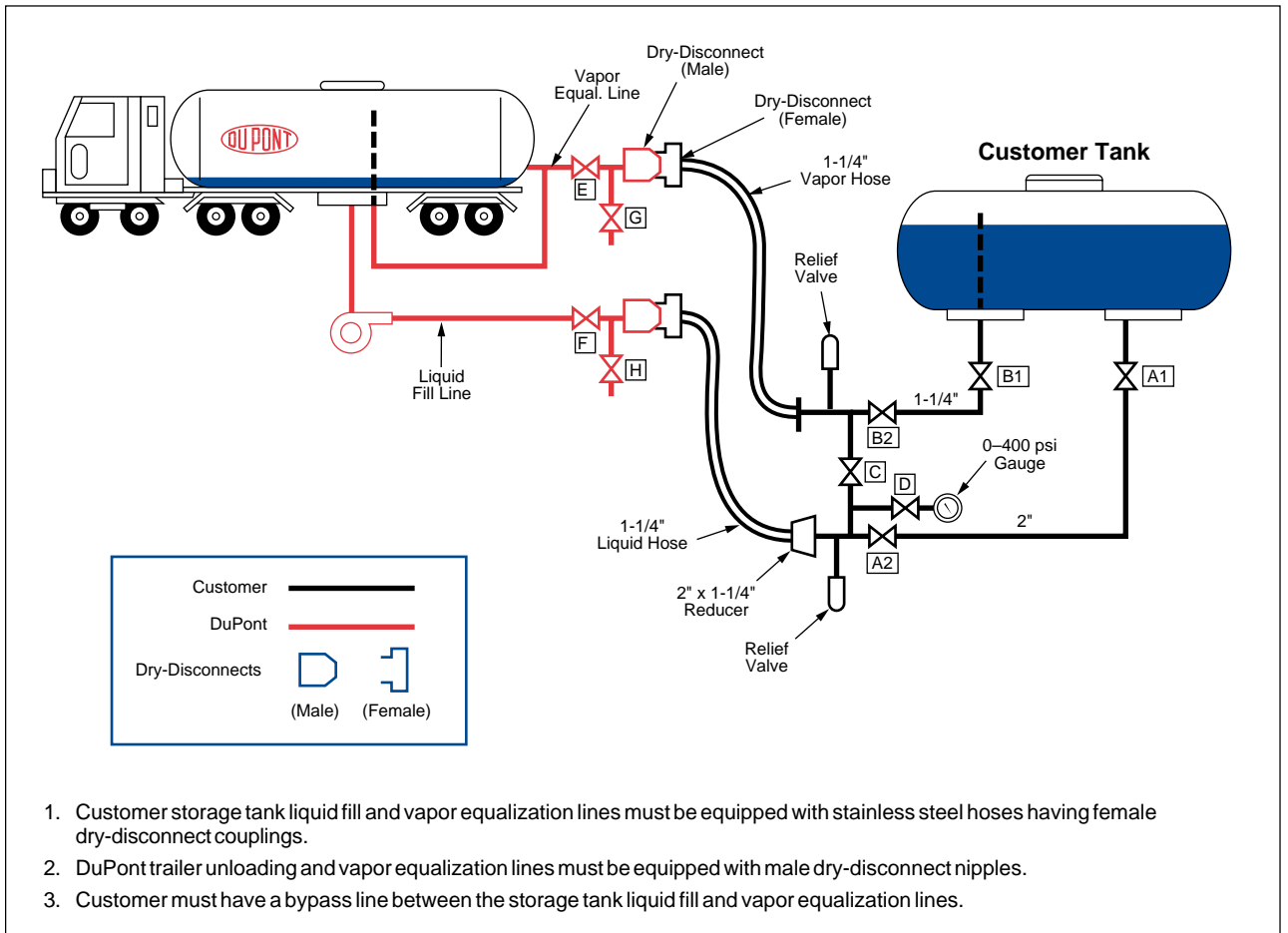
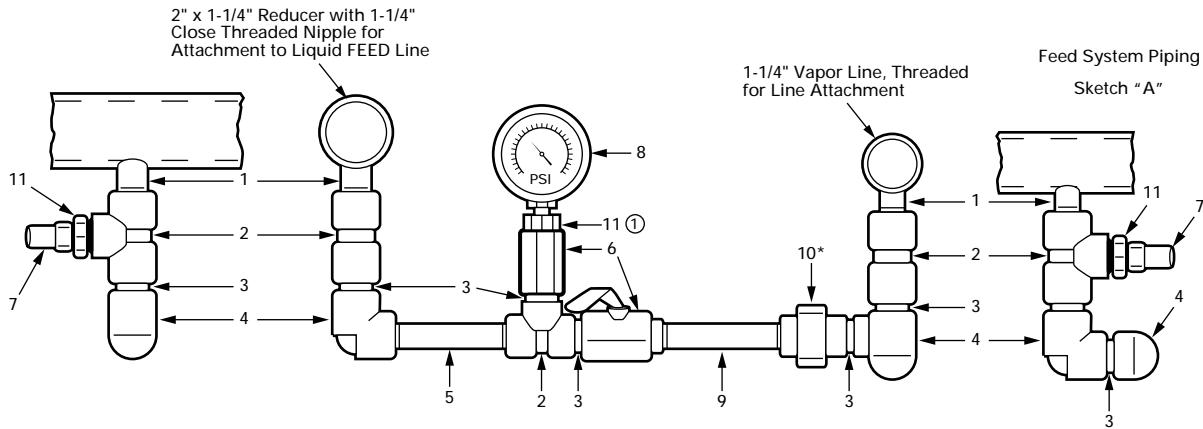

Figure 9. Liquid/Vapor Bypass Piping



3	11	Bushing/F.S. Thr'd.—1/2" x 1/4"	—	SA-105	①
1	*10	Union/F.S. Thr'd. 3000# *(300 lb. Raised-Face Flange Is Preferred)	—	SA-105	
1	9	Nipple/Pipe 1/2" Sch. 80, SML's. (Shop Fit) T.B.E.	0.147"	SA-106-B	
1	8	Pressure Gauge 0-400 lb. (Included with FEED System)	—	—	
2	7	Hydrostatic Pressure Relief Valve (Included with FEED System)	—	—	①
2	6	1/2" Ball Valve	—	—	
1	5	Nipple/Pipe 1/2" Sch. 80, SML's. x 4" Long T.B.E.	0.147"	SA-106-B	
3	4	ELL/F.S. Thr'd.—1/2" 2000#, 90 Deg.	—	SA-105	
6	3	Nipple/Pipe—1/2" Sch. 80, SML's. Close Thread	0.147"	SA-106-B	
3	2	Tee/F.S. Thr'd.—1/2" 2000#	—	SA-105	
2	1	Nipple/Pipe—1/2" Sch. 80 SML's. T.O.E.	0.147"	SA-106-B	
QTY.	NO.	DESCRIPTION	THK.	MATERIAL	

NOTE: All Threaded Piping Should Be New and Connections Made Using Felpro "Tight" Pipe Dope on All Joints (Or Use a Welded System).

SKETCH OF: (DUPONT FEED SYSTEM)
FLUORO-CHEMICAL EMISSIONS ELIMINATION DELIVERY SYSTEM

Hose Maintenance and Inspection

Purpose

This procedure provides guidance on inspecting the stainless steel hoses used for the DuPont FEED system.

General

In this procedure, hose service is classified as chemical-transfer hose. The hoses are typically used to unload tank trucks or tank cars, so they are subject to repeated connecting and disconnecting.

Visual Inspection

The hose should be extended to its full length in a clean, dry area and have its internal pressure removed. The external surface of the hose should be cleaned of foreign matter that might interfere with visual inspection. Each hose and coupling assembly should be flexed in all directions during the visual inspection and completely and carefully examined for any defects indicating a weakness that might render the assembly unfit for service.

- Cuts or nicks in the hose structure are indications of possible weaknesses caused by contact with sharp objects that might cut into the outer braid or inner tubular hose structure. Cuts or nicks that have damaged the inside tubular material of the hose are cause for hose rejection. Small cuts or nicks in the outer layer only are not cause for rejection unless the cover in the immediate area is loose or the inside tubular material has been cut or exposed.
- Minor fraying of the outer stainless steel braid, while not a cause for rejection, is a potential safety hazard. Gloves must be worn when handling hoses to avoid cuts due to burrs from fraying.

- Bulges, flat spots, or kinks are cause for rejection. Bulges may appear as swollen areas and generally indicate loss of hose strength due to deterioration of the inside tubular material. A flat spot is a deformation caused primarily by forceful contact with a blunt object (for example, crushed under the wheels of a vehicle). A kink is a short, tight twist or doubling of the hose upon itself, resulting in damage to the inner tubular material.
- Coupling damage due to wear, exposure, or abuse may appear as cracks, dents, or corrosion that create misalignment of the hose or coupling. Evidence of coupling damage is cause for hose rejection or coupling replacement. Damage to or excessive wear of the threaded or other connecting surface of a hose coupling is also cause for hose rejection or coupling replacement.
- Hose leaks may result from a number of conditions: hose punctures, deterioration of the inner tubular liner, coupling defects.
- Aging and weathering of a hose involves a gradual deterioration of the hose materials due to the action of time or exposure to the product transferred and may be evidenced by deterioration of the outer cover (stainless steel braid) or by coupling corrosion.

Even if free of any observable defects, the hose should be retired from use after five years of service.

Defect Removal

A hose assembly found with any defects must be removed from service. If repairs are not possible, the hose must be cut in half and discarded.

Inspection Frequency

Hoses should be visually inspected at least once a year.

For further information regarding DuPont™ Formacel®, contact:
www.dupont.com/formacel

United States

DuPont Fluorochemicals
CRP702-1274E
Wilmington, DE 19880-0702
Phone: (800) 969-4758
Fax: (302) 999-4727

Europe

DuPont de Nemours
International S.A.
2 Chemin du Pavillon
P.O. Box 50
CH-1218 Le Grand-Saconnex
Geneva, Switzerland
41-22-717-5111

Canada

DuPont Canada, Inc.
P.O. Box 2200, Streetsville
Mississauga, Ontario
Canada
L5M 2H3
(905) 821-3300

Mexico

DuPont, S.A. de C.V.
Homero 206
Col. Chapultepec Morales
C.P. 11570 Mexico, D.F.
52-5-722-1100

South America

DuPont do Brasil S.A.
Alameda Itapecuru, 506
Alphaville 06454-080 Barueri
São Paulo, Brazil
55-11-7266-8263

DuPont Argentina S.A.
Casilla Correo 1888
Correo Central
1000 Buenos Aires, Argentina
54-1-311-8167

Pacific

DuPont Australia
P.O. Box 930
North Sydney, NSW 2060
Australia
61-2-923-6165

Japan

Mitsui DuPont Fluorochemicals Co.,
Ltd.
Chiyoda Honsha Bldg.
5-18, 1-Chome Sarugakucho
Chiyoda-Ku, Tokyo 101-0064 Japan
81-3-5281-5805

Asia

DuPont Taiwan
P.O. Box 81-777
Taipei, Taiwan
886-2-514-4400

DuPont China Limited
P.O. Box TST 98851
1122 New World Office Bldg.
(East Wing)
Tsim Sha Tsui

Kowloon, Hong Kong
Phone: 852-734-5398
Fax: 852-236-83516

DuPont Thailand Ltd.
9-11 Floor, Yada Bldg.
56 Silom Road
Suriyawongse, Bankrak
Bangkok 10500
Phone: 66-2-238-0026
Fax: 66-2-238-4396

DuPont China Ltd.
Rm. 1704, Union Bldg.
100 Yenan Rd. East
Shanghai, PR China 200 002
Phone: 86-21-328-3738
Telex: 33448 DCLSH CN
Fax: 86-21-320-2304

DuPont Far East Inc.
6th Floor Bangunan Samudra
No. 1 JLN. Kontraktor U1/14, SEK U1
Hicom-Glenmarie Industrial Park
40150 Shah Alam, Selangor Malaysia
Phone 60-3-517-2534

DuPont Korea Inc.
4/5th Floor, Asia Tower
#726, Yeoksam-dong, Kangnam-ku
Seoul, 135-082, Korea
82-2-721-5114

DuPont Singapore Pte. Ltd.
1 Maritime Square #07 01
World Trade Centre
Singapore 0409
65-273-2244

DuPont Far East, Philippines
8th Floor, Solid Bank Bldg.
777 Paseo de Roxas
Makati, Metro Manila
Philippines
Phone: 63-2-818-9911
Fax: 63-2-818-9659

DuPont Far East Inc.
7A Murray's Gate Road
Alwarpet
Madras, 600 018, India
91-44-454-029

DuPont Far East Inc.—Pakistan
9 Khayaban-E-Shaheen
Defence Phase 5
Karachi, Pakistan
92-21-533-350

DuPont Far East Inc.
P.O. Box 2553/Jkt
Jakarta 10001, Indonesia
62-21-517-800

The information contained herein is based on technical data and tests which we believe to be reliable and is intended for use by persons having technical skill, at their own discretion and risk. Because conditions of use are outside of DuPont control, we can assume no liability for results obtained or damages incurred through the application of the data presented.

