

# DuPont™ ReliatraN™

## TRANSFORMERS MADE WITH DUPONT™ NOMEX®

### Single Phase Submersible Solid Insulation Distribution Transformer (SIDT)



DuPont™ ReliatraN™ solid insulation distribution transformer (SIDT) represents a major advancement in technology, featuring high short circuit strength, maintenance free exterior polymer shell and dielectric system and improvements in operating safety. SIDTs are designed for sub-surface installations therefore high and low voltage connections are inaccessible to the public. Next, they are oil-free, and as a result, testing has shown that when subjected to a sustained fault condition, an SIDT failure mode is less severe. Finally, SIDT construction is fire-resistant and self extinguishing. The technology was tested to, and complies with, IEC Standard 60076-11 fire behavior test F1 Class.

ReliatraN™ transformers fulfill the public preference for improved aesthetics - total underground distribution systems - while meeting the Utility industry's environmental desire for fluid-free transformers.

ReliatraN™ transformers, protected by their non-metallic outer shell, can operate in diverse underground environments. They are an ideal choice where environmental concerns about soil or groundwater contamination, or public exposure to mineral oil may occur. They afford distribution system design engineers increased flexibility in locating transformers while helping to increase operating safety and system reliability. Improved SIDT reliability features include: longer short circuit withstand time which exceeds

applicable Industry Standards and proven by testing; the use of Nomex® paper for extending critical insulation life; and the use of 100% solid dielectrics which can't leak and therefore diminish service life.

#### Ratings

- kVA: 25, 50, 75, 100, 167
- 100°C average temperature rise
- Low Voltages: 240/120, 120/240, 480/240, 277, 347, 480, 575
- High Voltages: single ratings from 4160GY/2400 through 27,700GRDY/16,000
- BIL: High Voltage 60 to 125kV, Low Voltage 30kV
- Impedance range 2.5% - 3.5%
- Sound Level less than 50dB

#### Product Construction

The unique combination of high performance insulating materials including DuPont™ Nomex® 220°C UL rated paper, shielded composite envelope and a simple, yet highly effective, thermal design helps enable the ReliatraN™ to be applied with versatility and confidence.

The electrical insulation system is comprised entirely of solid materials without any fluids or gases. Generally, the transformer technology consists of windings that are totally impregnated and encapsulated, using an automatic pressure gellation (APG) process, with a thermally conductive, electrically insulating epoxy resin.

The transformer outer shell is constructed of durable polymer composite materials that offer excellent mechanical strength, and resistance to moisture and corrosion.

### Application

Advanced design characteristics yield a distribution transformer well suited for use in a variety of applications, including:

- Residential, commercial and urban underground distribution
- Indoor protected commercial structures
- Corrosive environments
- Damp or humid areas
- Waterfront locations
- Industrial facilities
- Areas prone to storms and flooding

### Considerations

1. High voltage and low voltage terminations are molded integrally to the transformer.
2. The SIDT is completely sealed construction, internal access is not possible.
3. Switching devices, if necessary, must be located externally.
4. Primary or secondary fuse protection must be applied separately.

### Key Features

- All high and low voltage connections in SIDT underground installations are inaccessible to the public
- Free of mineral oil or other volatile liquids that are also unsafe for the environment
- Construction is fire resistant and self-extinguishing
- Maintenance free exterior shell and dielectric system
- High short circuit strength – epoxy impregnated conductors are virtually “locked in place”
- Low sound level

### Certification Tests

- Short circuit, IEEE C57.12.90
- Special destructive short circuit
- Fire Behavior, IEC 60076-11
- Emissions, IEC 60076-11
- Special thermal shock
- Special immersion and chemical resistance

For more information see the DuPont™ ReliatraN™ Installation/Maintenance Manual.

### Installation

1. Single, universal, 200A bushing well is molded into the SIDT for primary connection. Dual primary bushing wells are available as an option.
2. Threaded stud is removable.
3. Ground bus bar is externally located for cable connection.
4. Flexible cable leads 90cm (35.43”) are supplied standard for secondary connections. Optionally, cables may be extended to meet specific customer requirements.
5. SIDT is designed for underground installation and operation in a vault or enclosure.
6. Retrofit into existing underground vaults may be accomplished with minimal difficulty.
7. Accessories must be mounted externally to the SIDT.

### Approximate weights (kg/lbs) and maximum dimensions (mm/inch)

kVA	Weight	A	B	C*
	kg(lbs)	mm(inch)	mm(inch)	mm(inch)
25	370 (820)	515 (20.3)	510 (20.0)	445 (17.5)
50	410 (910)	585 (23.0)	580 (22.8)	490 (19.3)
75	500 (1100)	705 (27.8)	580 (22.8)	490 (19.3)
100	610 (1350)	775 (30.5)	625 (24.5)	560 (22.0)
167	950 (2100)	940 (37.0)	715 (28.2)	610 (24.0)

\*Add 6” for lead projection for 25-50 kVA and 8” for 75-167 kVA

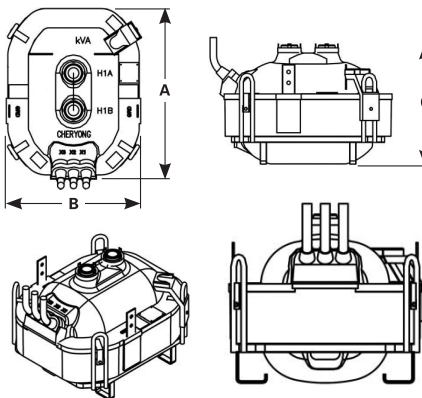

### Typical Product Specifications:

1. Transformer shall contain no oil, gas, combustible liquids or cellulose insulation.
2. The transformer exterior surface and dielectric system do not require maintenance.
3. Exterior surfaces, exclusive of ground bus, will be made of completely non-metallic construction.
4. The transformer shall be suitable for below ground operation partially or fully submerged in water.
5. The transformer will be designed for a maximum of 100°C internal average temperature rise above ambient at rated load.

PRODUCT SAFETY INFORMATION IS AVAILABLE UPON REQUEST. THIS INFORMATION CORRESPONDS TO OUR CURRENT KNOWLEDGE ON THE SUBJECT. IT IS OFFERED SOLELY TO PROVIDE POSSIBLE SUGGESTIONS FOR YOUR OWN EXPERIMENTATIONS. IT IS NOT INTENDED TO SUBSTITUTE, HOWEVER, FOR ANY TESTING YOU MAY NEED TO CONDUCT TO DETERMINE THE SUITABILITY OF OUR PRODUCT FOR YOUR PARTICULAR PURPOSES. THIS INFORMATION MAY BE SUBJECT TO REVISION AS NEW KNOWLEDGE AND EXPERIENCE BECOME AVAILABLE. SINCE WE CANNOT ANTICIPATE ALL VARIATIONS IN ACTUAL END USE CONDITIONS, DUPONT MAKES NO WARRANTIES AND ASSUMES NO LIABILITY WHATSOEVER IN CONNECTION WITH ANY USE OF THIS INFORMATION. NOTHING IN THIS PUBLICATION IS TO BE CONSIDERED AS A LICENSE TO OPERATE UNDER OR INFRINGE ANY TRADEMARK OR PATENT RIGHT.

DuPont Advanced Fibers Systems  
 Customer Inquiry Center  
 5401 Jefferson Davis Highway  
 Richmond, VA 23234  
 Tel: 800.931.3456  
 Fax: 800.787.7086  
 email: [afscdt@usa.dupont.com](mailto:afscdt@usa.dupont.com)

[www.nomex.com](http://www.nomex.com)



The miracles of science™