

This addendum describes how to enhance bath designs with hard seam wetwalls and thermoformed corners of CORIAN®. These procedures should be used in conjunction with the CORIAN® Wetwall Guide, H-03836.

Addendum to Wetwall Guide:

Enhancing the Design of Tub and Shower Surrounds with Hard Seams and Corner Treatments

This addendum contains detailed procedures for fabricating and installing customized CORIAN® wetwall systems for tub and shower surrounds. The special treatments described in this guide include:

- Making hard seam wetwalls;
- Thermoforming overlay corners;
- Creating flush thermoformed corners in one color or contrasting colors; and
- Using running or thermoformed trim.

These special treatments enable you to enhance bath suite designs and to increase your sales

opportunities by giving you the design flexibility to create upscale, contemporary or traditional tub and shower surrounds. And, by combining corner treatments and contrasting trim of CORIAN® with other design options, such as tub decking, steps, custom vanity tops, lavatories, wainscoting and bath accessories, you can further increase your sales opportunities in both new construction and bath remodeling markets.

Hard Seaming Wetwalls

Project Profile: This treatment allows you to create smooth, one-piece back and side walls by using Joint Adhesive to seam together 1/4" sheets of CORIAN® that are wider than 30". There are two methods that can be used to achieve this "no seam" appearance:

- Butt joint method
- Reverse batten method

Skill Level: Intermediate.

Fabrication Time: 1½ hours in shop per hard seam.

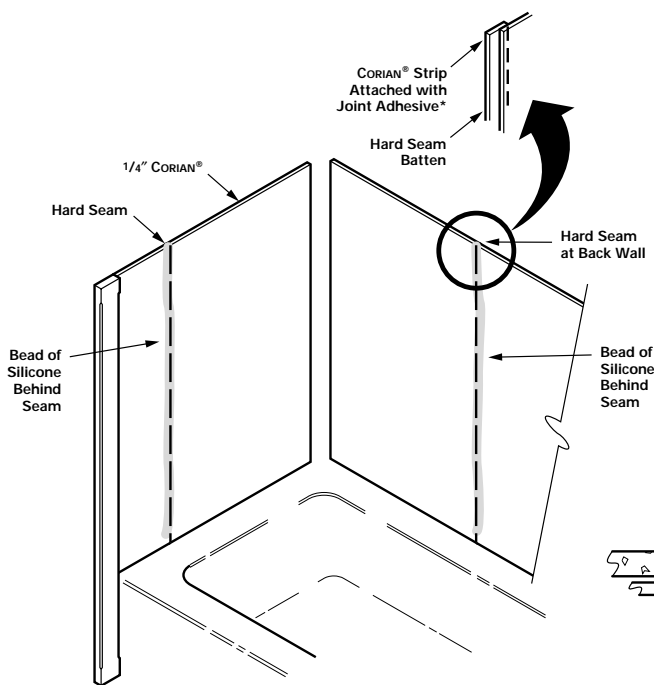

***Note:** All field hard seams require a reverse hard seam batten to assure alignment and a watertight fit. This is necessary because a silicone bead cannot be applied behind a field hard seam.

To create a reverse hard seam batten, notch the gypsum board and attach a CORIAN® strip to the underside of the wall panel before installation.

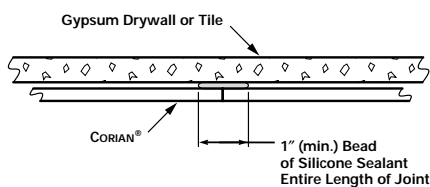

(continued)

CORIAN®
SURFACES
Created For Life.™



Installation Considerations: Both methods require two people to handle and install hard-seamed sheets on the job site. The butt joint method eliminates the need to caulk and detail (batten strips or easing) back and side wall seams on the job site. The reverse batten method strengthens the seam for easier handling during transportation and installation. It also provides greater resistance to cracking.

Advantages:

- Gives clean, one-piece look.
- Reduces maintenance.

Procedure:

There are two methods that you can choose from to fabricate and install a solid seam wetwall of CORIAN®.

Method #1 — Butt Joint

1. Using Joint Adhesive, seam together ¼" sheets of CORIAN® for the back and side walls in the shop. Follow the same procedure you would use for making island or peninsula seams for kitchen countertops. Refer to the Fabrication Guide for details.
2. When transporting the seamed walls to the job site, use these precautions as a guide to prevent joint failure:
 - Attach a sheet of plywood to the back of the seamed CORIAN® to facilitate transporting.
 - Do not handle large, seamed pieces single-handedly; two installers are required.

- Carry seamed pieces vertically whenever possible.
- Transport flat in a truck or van; glass racks are useful, if available.
- Use 2 x 4 frames to protect the pieces during transport.

3. When installing hard-seamed wetwalls, two people are required. Glass suction cups are helpful.
4. Be sure the ends of the joint are sanded smooth to prevent stress risers from forming.
5. Place a heavy bead of Silicone Sealant on the back side of the sheet, directly over the hard seam, before applying the sheets to the wall. Should the seam break apart, this is a moisture barrier to prevent water damage before the repair is completed.

Note: Do not locate control valves through seams because CORIAN® is vulnerable to stress cracking when escutcheon plates are overtightened.

6. Finish the installation by enhancing with one of the corner treatments described in this addendum.

(continued)

CORIAN®
SURFACES
Created For Life.™



Method #2—Reverse Batten

1. Reinforce the seam by applying a strip of 1/4" CORIAN® to the backside of the sheets of CORIAN®. Be sure to:
 - Use a strip similar in color to the sheets.
 - Sand the strip to remove chips and nicks.
 - Seam the sheets face down on a flat surface.
 - Attach the reinforcing strip to the seam with Joint Adhesive during seaming to help protect the seam during finishing. Be sure to use enough adhesive to prevent gaps.
 - Use clamps to pull the seam together.
 - Use weights to hold the strip to the sheets.
2. Prepare the drywall using one of the options shown below:
 - Option 1— Cut away the drywall to fit the reinforcing strip.
 - Option 2— Cut a shallow groove or trench in the drywall.
 - Option 3— Use spacers to position the CORIAN® away from the wall.
3. Install the reinforced wetwall panel by attaching it to the substrate, using one of the methods illustrated below.
4. Follow all the other procedures described on pages 42 to 51 of the *Wetwall Guide* (H-03836).

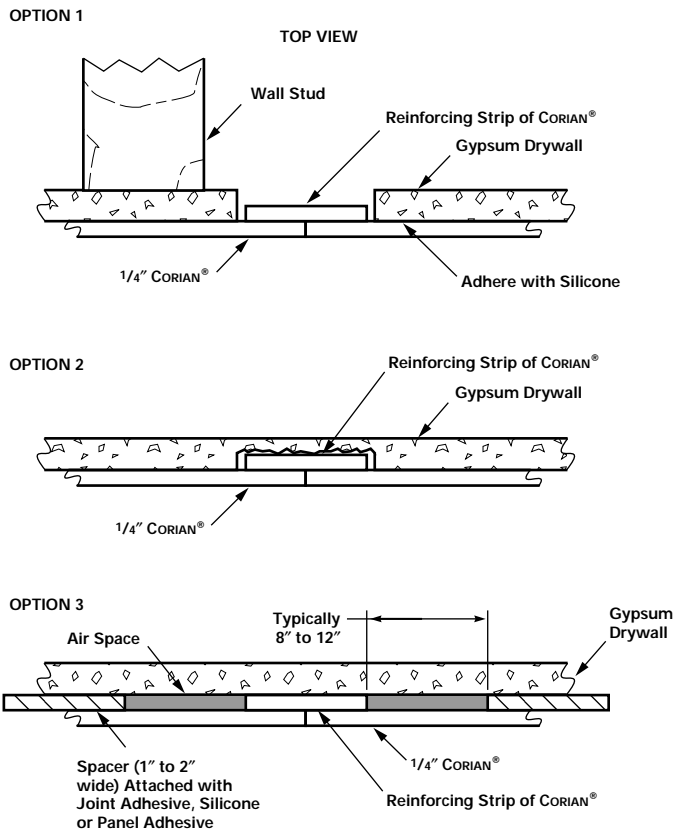

(continued)

Making Overlay Corners

Project Profile: This treatment allows you to create upscale, contemporary shower and bath designs that incorporate thermoformed corners of CORIAN® over the back and side walls.

Skill Level: Basic.

Fabrication Time: Thermoforming time, plus ½ hour for routing the edges on two thermoformed corners (four edges).

Installation Considerations: Reduces installation time by up to 1 hour by eliminating the need to scribe.

Advantages

- Gives a clean, custom corner appearance.
- Allows contrasting colors to be used in corner treatments.
- Allows you to rout the corner edges for greater design flexibility and increased sales opportunities.

- Saves time on commercial installations by allowing you to work from nominal dimensions.

Procedure:

1. Rout the edges of the corner pieces in the shop to enhance their appearance.
2. To install, adhere CORIAN® to the back and side walls, leaving an air gap.
3. Place a bead of Silicone Sealant on the back and side walls of CORIAN® behind the overlay corner, back from the edge.

Note: Allow a minimum overlap of 1" for all silicone seams.

4. Use Silicone Sealant to caulk leading edges to the back and side walls.

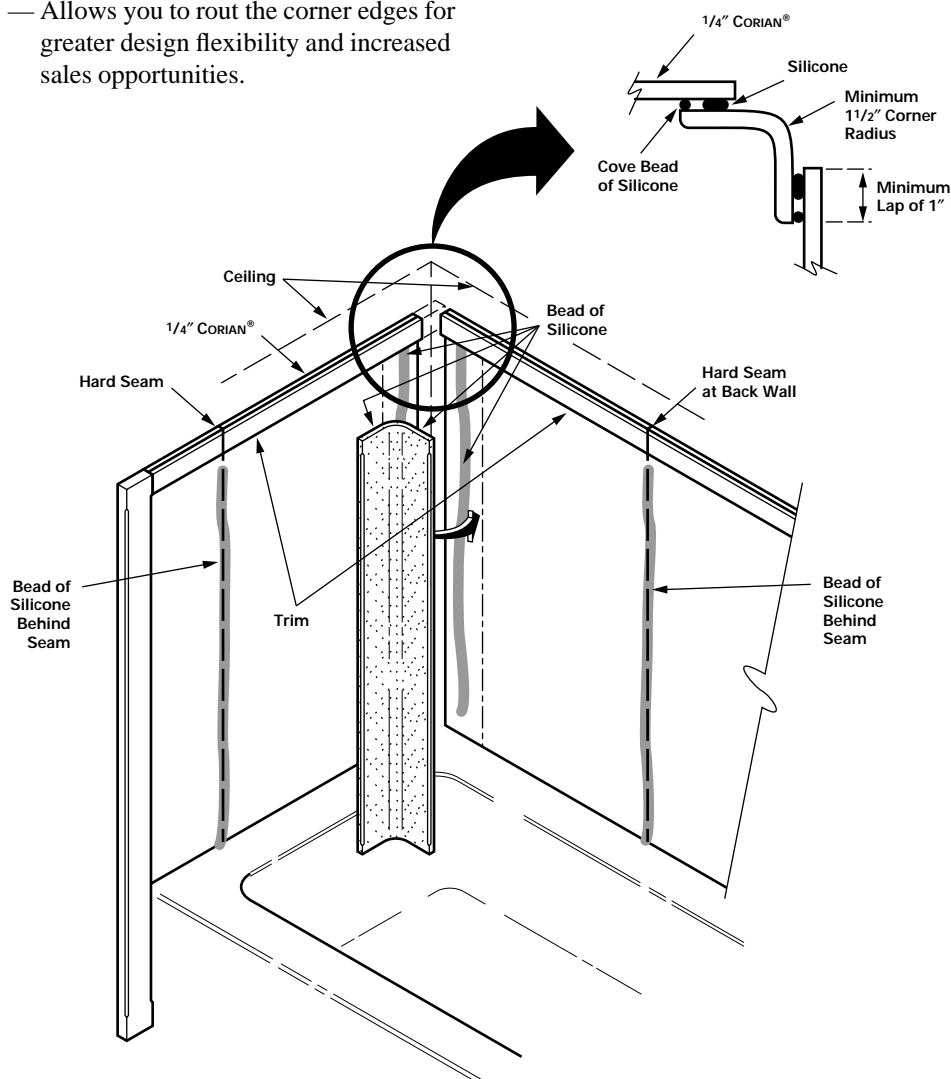

(continued)

CORIAN®
SURFACES
Created For Life.™



Making Flush, Caulked Thermoformed Corners

Project Profile: This treatment allows you to create almost a one-piece look with curved corners. It can be combined with the thermoformed trim described later.

Skill Level: Intermediate; requires good fitting skills.

Fabrication Time: Thermoforming time, plus 1½ hours in the shop per hard seam (back and side walls).

Installation Considerations: Increases installation time by at least 1 hour since fit and tolerances are critical; shimming may be necessary to ensure flush surfaces.

Advantages

- Allows you to achieve a continuous, curved look.

- Works well with hard-seamed back and side walls.
- Reduces maintenance.

Procedure:

1. To install, ease or bevel the edges of the thermoformed corners and the adjoining back and side walls.
2. Place a bead of Silicone Sealant on the back side of the first thermoformed corner to be installed before applying it to the wall. Adhere the corner to the wall.
- *Helpful Hint:* Hot melt glue laminate strips to the underside of the corner piece to help align it with the wall sheet.
3. Leave a 1/16" gap between this corner and the adjoining back and side walls of CORIAN®.
4. Place a bead of Silicone Sealant on the back side of the wall sheets (near the edges) before applying them to the wall. Adhere the back and side walls, making sure they are flush. Shimming may be needed.
5. Install thermoformed trim, if desired.

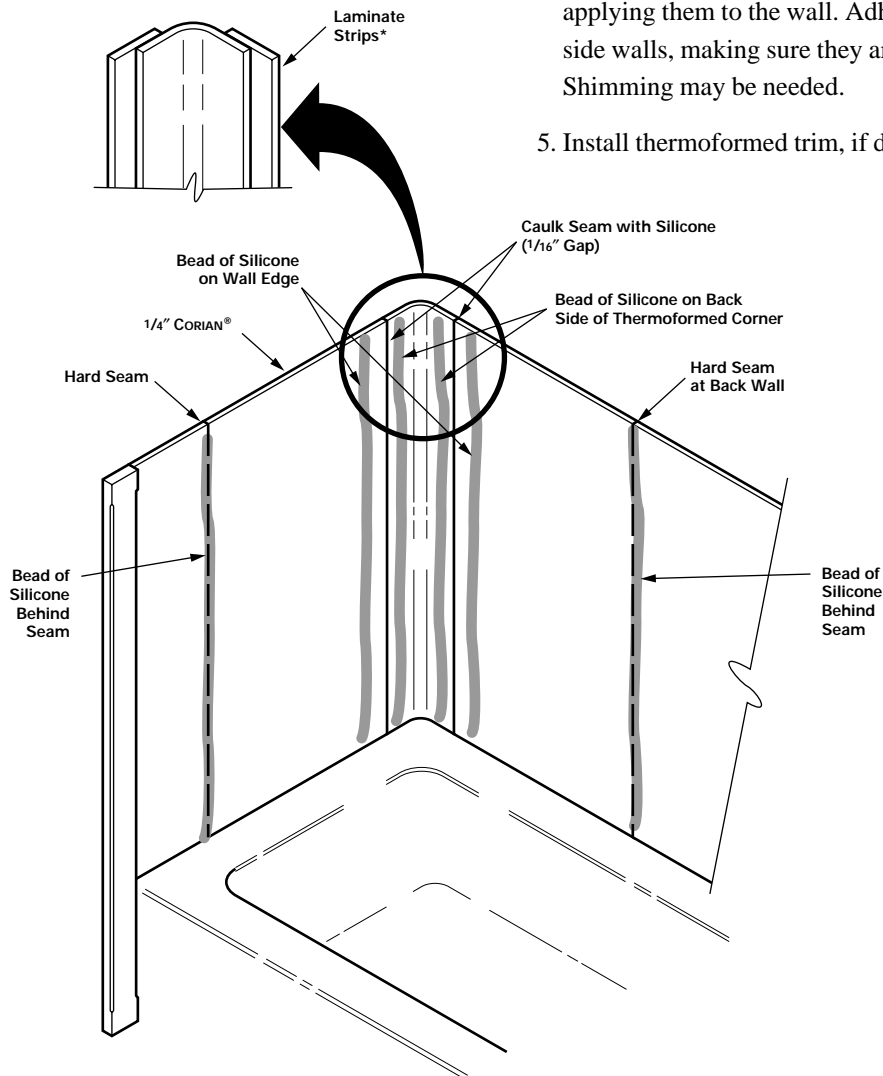

(continued)

CORIAN®
SURFACES
Created For Life.™



Making One-piece, One-color Thermoformed Corners

Project Profile: This treatment allows you to create custom one-piece looks with curved corners color-matched to the back and side walls.

Skill Level: Advanced.

Fabrication Time: Thermoforming time, plus 1½ hours in the shop per hard seam. Two sheets (one hard seam) will serve back walls 48" and under. Three sheets (two hard seams) are required for back walls over 48".

Installation Consideration: 3 hours per field seam, plus additional fitting and shimming as needed to ensure flush surfaces. Walls should be plumb and square. If they're not, measurements should be based on the minimum plumb opening possible.

Advantages:

- Allows you to achieve a continuous, one-color curved look.
- Works well with hard-seamed back and side walls.
- Reduces maintenance.

Procedure:

1. Using a level, measure the back wall to determine the minimum plumb opening possible.
2. Thermoform a 1½" radius into the ends of each 30" back wall sheet. The corner wings should measure approximately 6".

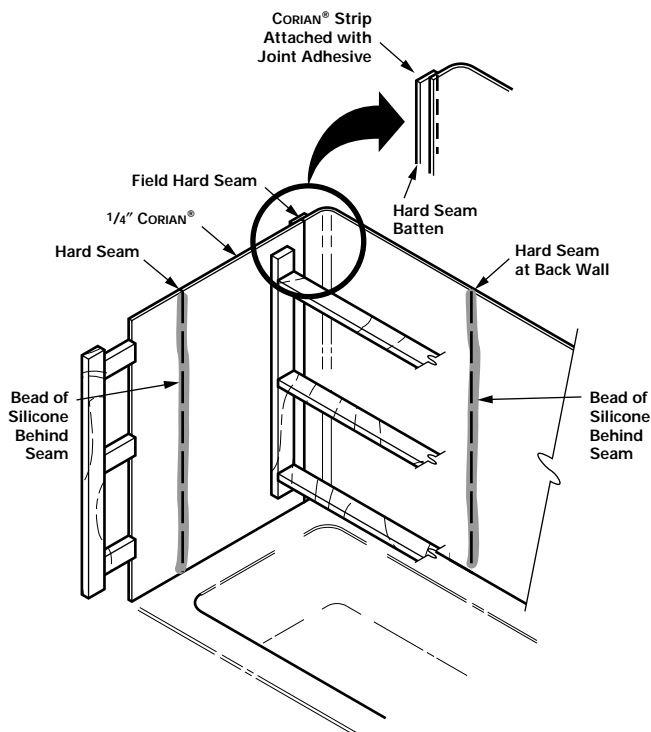

3. Cut to fit the installation's dimensions and hard seam together with Joint Adhesive.

Note: All field hard seams require a reverse hard seam batten to assure alignment and a watertight fit. This is necessary because a silicone bead cannot be applied behind a field hard seam.

To create a reverse hard seam batten, notch the gypsum board and attach a CORIAN® strip to the underside of the corner wall panel before installation.

4. Square off the corner edges to prepare for seaming.
5. Attach laminate strips or chips to the back of each corner, allowing a ¼" minimum overhang for aid in alignment.
6. Adhere the back wall with Silicone Sealant and hot melt glue.
7. Dry fit the side walls. Tack 6" wide plywood strips on end walls with hot melt glue. Place several 2x's or equivalent braces between them. Check for plumbness and adjust as needed. (Cut remaining braces for later use.)
8. Prepare and clean the field seam area. Tape off the tub or shower base to protect it from adhesive.
9. Apply Silicone Sealant to the back of the sheet and apply the sheet to the side wall, leaving a ⅛" to ⅙" gap for Joint Adhesive.
10. Apply Joint Adhesive to the edge of the sheet and slide to the edge of the corner/back wall piece.
11. Apply braces between side walls, working from the top to the bottom.
12. Check the seam and add or remove adhesive as needed.
13. After the seam sets, remove the braces. Finish the seam.

(continued)

CORIAN®
SURFACES
Created For Life.™



Making One-piece, Contrasting-color Thermoformed Corners.

Project Profile: This treatment allows you to create custom one-piece looks with curved corners in contrasting colors of CORIAN®.

Skill Level: Advanced.

Fabrication Time: Thermoforming time, plus 1½ hours in the shop per hard seam.

Installation Considerations: 3 hours per field seam, plus additional fitting and shimming as needed to ensure flush surfaces. Walls should be plumb and square. If they're not, measurements should be based on the minimum plumb opening possible.

Advantages:

- Allows you to achieve a continuous look with curved corners in contrasting colors of CORIAN®.
- Works well with hard-seamed back and side walls.
- Reduces maintenance.

Procedure:

Follow the fabrication and installation instructions previously described for One-piece, One-color Thermoformed Corners, omitting step 2.

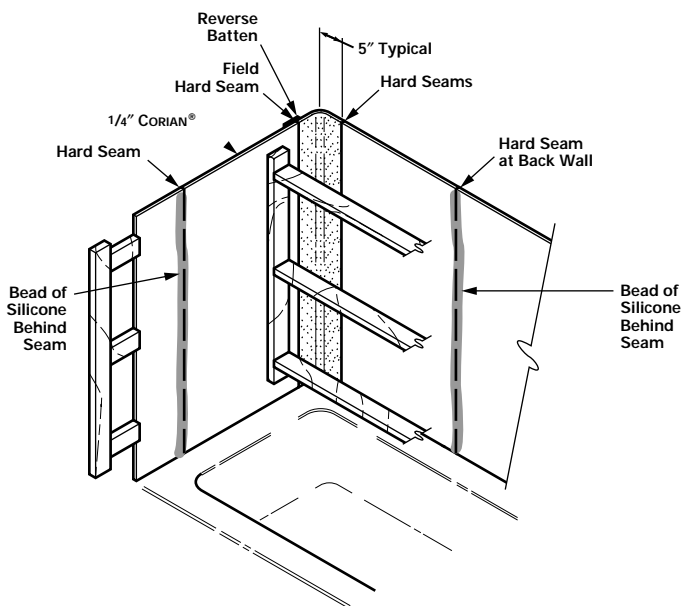

(continued)

Making Running Trim

- Use at the top and at vertical jambs.
- Use Option 1 when the top of the trim will be visible.
- Use Option 2 when the trim will go to ceiling. If the top of the trim will not go to the ceiling and will not be visible, use Option 2, but caulk and fill the gap.

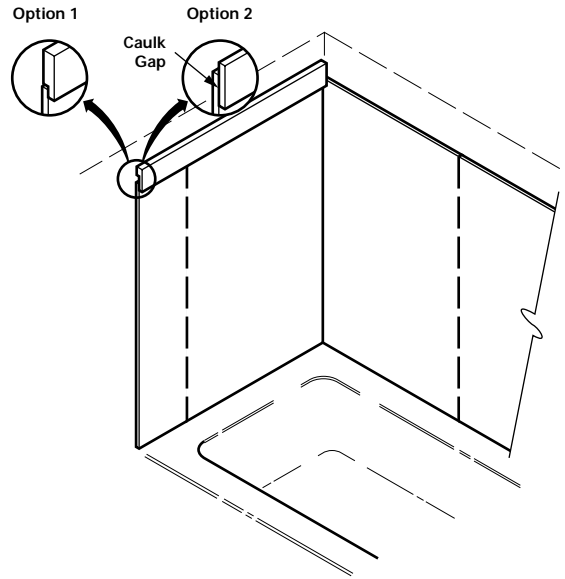

Making Thermoformed Trim

- Cut a 2" strip off the corner treatment for use as trim.
- Use at the top to accommodate thermoformed inside corners.
- Install before the corner treatment.
- Refer to the following illustrations for details.

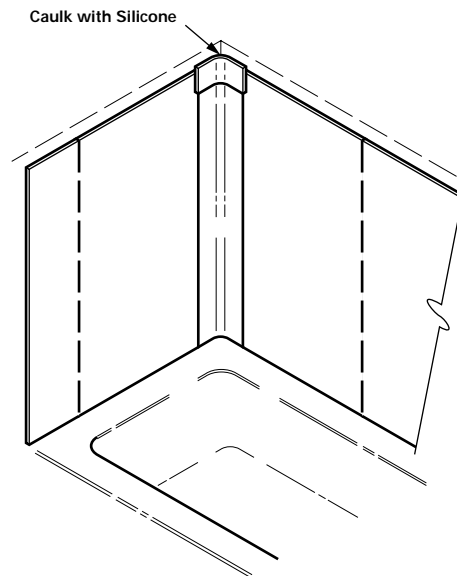

(continued)

CORIAN[®]
SURFACES
Created For Life.[™]



Trim Details for Installations Where Panels Do Not Go to Ceiling

Flush, Caulked Corners

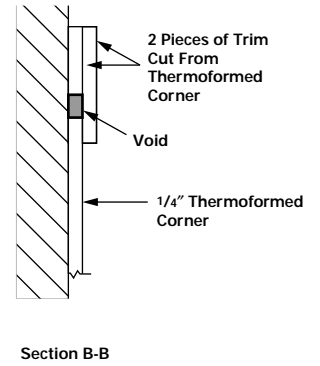
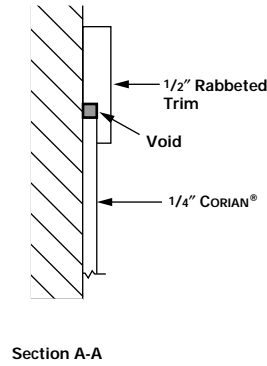
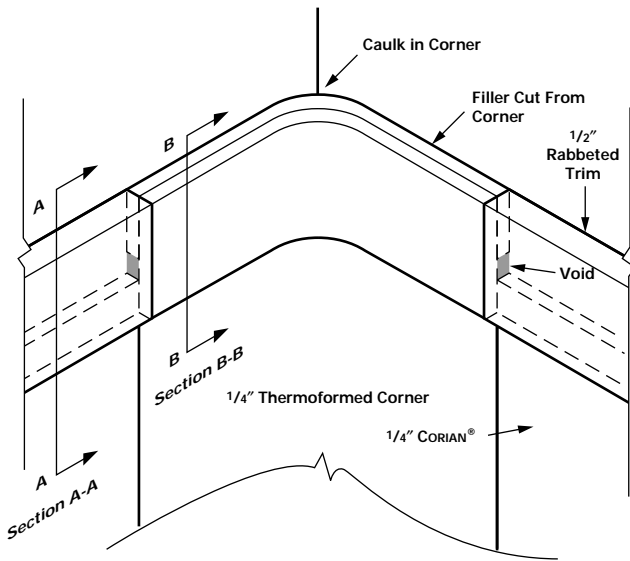

OVERLAY CORNER

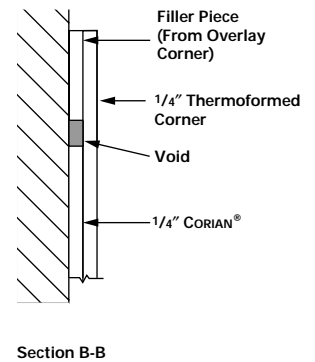
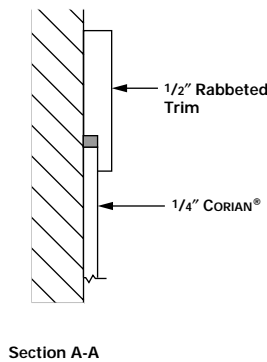
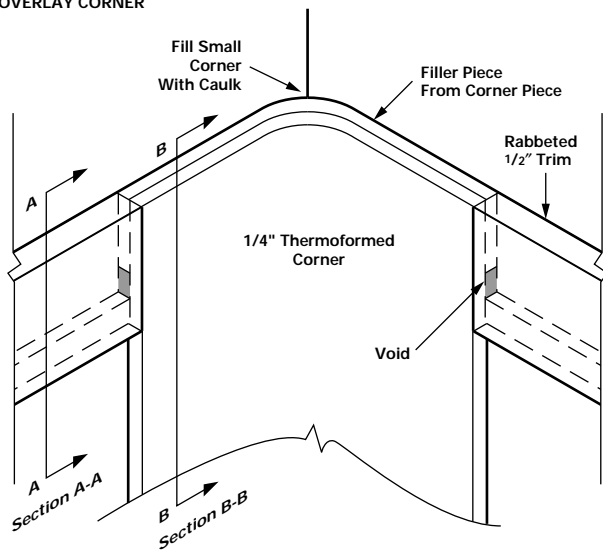

(continued)

**Section Through Form for
Bending $1\frac{1}{2}$ " Radius in $\frac{1}{4}$ " Mtl.
Along the Material's Length**

***Note:** If the hardwood radius inserts are interchangeable, this mold will provide greater flexibility for thermoforming different radii in all sheet thicknesses.

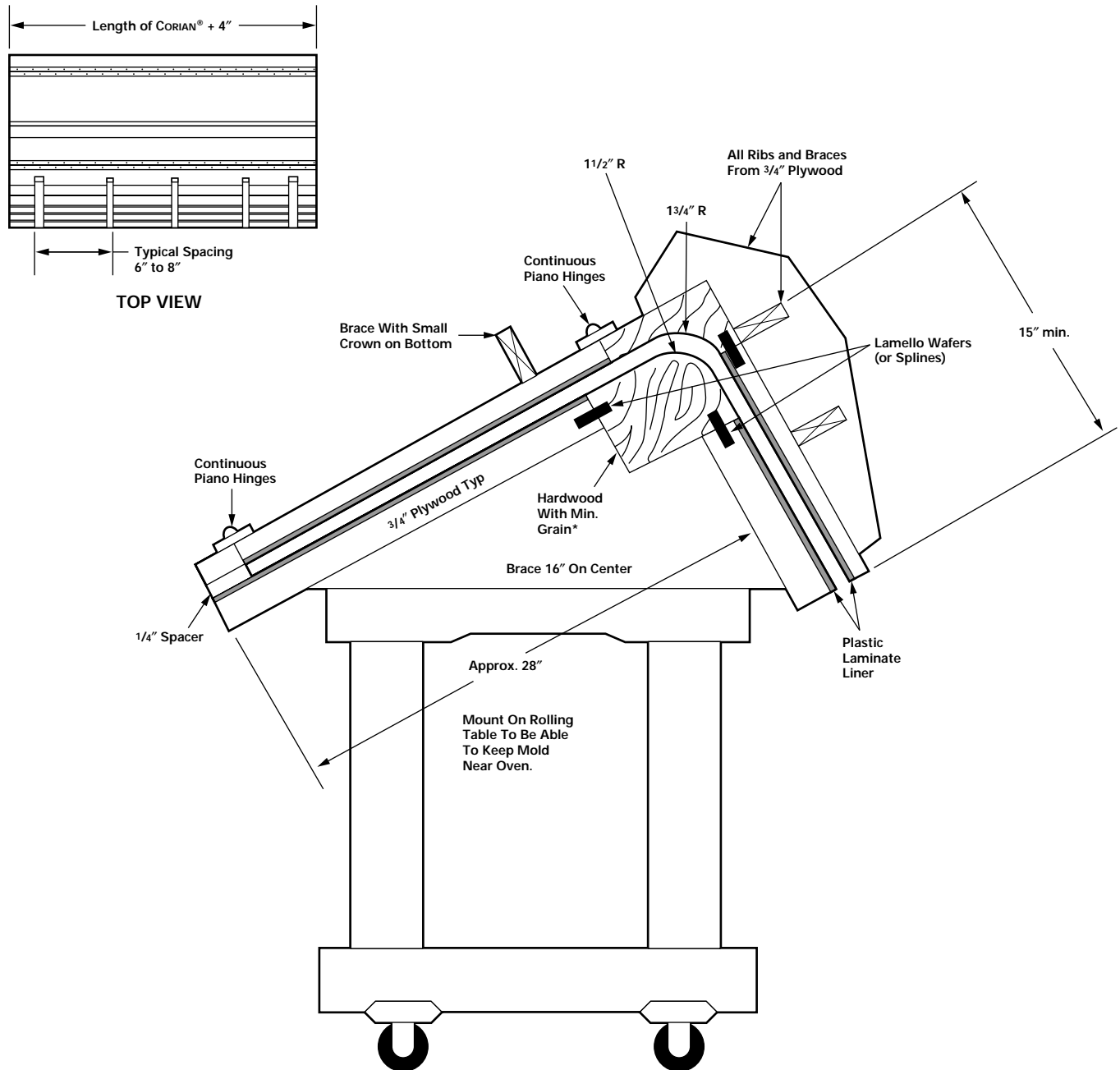

The information contained in this Technical Bulletin is given by E. I. du Pont de Nemours and Company free of charge. It is based upon technical data which DuPont believes to be reliable and is intended for use by persons having knowledge of this technical area at their own discretion and risk. Seller assumes no responsibility for results obtained or damages incurred from the use of this Technical Bulletin either in whole or in part by a buyer of CORIAN®.

CORIAN®
SURFACES
Created For Life.™

