



DuPont™
FlexWrap

DuPont™
StraightFlash VF

DuPont™
StraightFlash

DuPont™
Commercial Sealant

DuPont™
FlexWrap™ NF

DuPont Flashing Systems Commercial Installation Guidelines

FOR DUPONT™ THRU-WALL FLASHING
BASE OF WALL WITH OUTSIDE CORNER



Tyvek.

Table of Contents

Applicable Products	2
Required Materials	2
Optional Materials	3
DuPont Recommended Primers.....	3
DuPont Recommended Fasteners	3
General Instructions	3
Surface Preparation for DuPont™ Thru-Wall Flashing	4
Installation Instructions for DuPont™ Thru-Wall Flashing	
Base of Wall With Outside Corner.....	...5

Applicable Products

DuPont Flashing Systems products

PRODUCT	DIMENSIONS	AREA
DuPont™ FlexWrap™	7 in x 75 ft	43.7 sq ft
	9 in x 75 ft	56.2 sq ft
	9 in x 250 ft	187.5 sq ft
DuPont™ FlexWrap™ NF	6 in x 75 ft	37.50 sq ft
	9 in x 75 ft	56.20 sq ft
DuPont™ StraightFlash™	4 in x 150 ft	50 sq ft
	9 in x 125 ft	93.75 sq ft
DuPont™ StraightFlash™ VF	6 in x 125 ft	62.5 sq ft
DuPont™ Thru-Wall Flashing	12 in x 75 ft	75 sq ft
	18 in x 75 ft	112.5 sq ft
	24 in x 75 ft	150 sq ft
	36 in x 75 ft	225 sq ft

Accessories

PRODUCT	TYPE	PER BOX
DuPont™ End Dams	4"	50 (25 left/25 right)
DuPont™ End Dams	6"	50 (25 left/25 right)
DuPont™ Corners	Inside	25
DuPont™ Corners	Outside	25

Necessary Materials

- DuPont Flashing Systems
- DuPont™ Tyvek® Tape
- DuPont™ Thru-Wall Flashing
- DuPont™ Corners (Inside and Outside)
- DuPont™ End Dams
- DuPont™ StraightFlash™, DuPont™ FlexWrap™, or DuPont™ Tyvek® Tape

Recommended Materials

- DuPont™ Tyvek® Wrap Cap Fasteners
- Backer Rod
- Brushes for Surface Preparation
- J-Roller
- Compatible Primers and Sealants
- DuPont™ Commercial Sealant
- “L” shaped back dam is a 3/4” corner guard (used on interior gypsum)

Required Materials Warranty

If interested in receiving warranty coverage, please see DuPont Weatherization Systems products 10 year limited warranty for buildings less than 5 stories and DuPont Weatherization Systems products 10 Year Limited Warranty for buildings greater than 4 stories.

DuPont Recommended Primers* (Flashing Only)

MANUFACTURER	PRODUCT NAME
3M	Hi-Strength 90
Denso	Butyl Primer (spray or can)
Henkel	SIA 655
Henkel	Permagrip® 105™
ITW TACC	STA'PUT SPH

* Apply per manufacturers' guidelines. DuPont assumes no liability in use of recommended products; installers need to evaluate suitability of recommended products in their end-use applications.

DuPont Recommended Fasteners*

MANUFACTURER	PRODUCT NAME
DuPont	DuPont™ Tyvek® Wrap Cap nails
DuPont	DuPont™ Tyvek® Wrap Cap screws
DuPont	DuPont™ Tyvek® Wrap Cap staples (for Stinger™)**

* Apply per manufacturers' guidelines. DuPont assumes no liability in use of recommended products; installers need to evaluate suitability of recommended products in their end-use applications.

** Not recommended with foam sheathing board or exterior gypsum.

General Instructions

DuPont Flashing Systems products should be installed on clean, dry surfaces that are free of frost. Wipe surfaces to remove moisture, dirt, grease and other debris that could interfere with adhesion.

Apply pressure along entire surface for a good bond using a J-roller or firm hand pressure.

Remove all wrinkles and bubbles by smoothing surface and repositioning as necessary.

When flashing the sill area for windows and doors, DuPont recommends the use of 7" wide DuPont™ FlexWrap™ for 2" x 4" framing and 9" wide DuPont™ FlexWrap™ for 2" x 6" framing. When rigid back dams are required or desired, an option would be to use a ¾" corner guard (back dam) cut to the length of the sill and nail into place on the interior edge of the sill prior to installation of DuPont™ FlexWrap™. Then install DuPont™ FlexWrap™ over sill and corner guard back dam.

Door and window rough sill framing must be level or slightly sloped to the exterior to ensure proper drainage to the exterior. Please contact your local DuPont™ Tyvek® Specialist for additional information and installation instructions.

DuPont™ Commercial Sealant should be tooled flat to allow the natural curing process to create a concave joint.

DuPont Flashing Systems Commercial Installation Guidelines

DO NOT STRETCH DuPont™ FlexWrap™ when installing along sills or jambs. DuPont™ FlexWrap™ is only intended to be stretched when covering corners or curved sections.

DuPont™ Flashing Systems products perform best when installed at temperatures above 25°F (-4°C).

Avoid placing DuPont™ Tyvek® Wrap Caps where flashing will be installed; however, DuPont™ Tyvek® Wrap Caps can be applied over the flashing.

Where buildings could be exposed to extreme weather conditions (ie. sustained wind-driven rain above 50mph), install a high pressure skirt to help prevent water intrusion at the sill.

For high pressure design loads, the use of DuPont™ Tyvek® StraightFlash™ with wrap cap screws is required to secure the head flap of the windows.

Priming is generally not required for adhering DuPont Flashing Systems products to most common building materials. However, adverse weather conditions or cold temperatures may require use of a primer to promote adhesion. Additionally, concrete, masonry, and fiber-faced exterior gypsum board require the use of recommended primers. For primer recommendations, see page 3.

Priming is required for DuPont™ Thru-Wall Flashing.

Surface Preparation for DuPont™ Thru-Wall Flashing

Substrate surface must be smooth, clean, dry, and free from voids, loose substrate, protrusions, or any material that would hinder adhesion of the flashing.

Clean the surface with a clean dry cloth or brush.

Follow primer manufacturers' guidelines for appropriate coverage and drying times.

Storage for DuPont™ Thru-Wall Flashing

DuPont™ Thru-Wall Flashing should be protected from rain and physical damage under cover at the job site.

Optimum storage temperature 50°F to 90°F.

Freeze-thaw durable. Storage temperatures should not exceed 120°F.

Environmental Conditions for DuPont™ Thru-Wall Flashing

DuPont™ Thru-Wall Flashing should not be applied to moist or damp surfaces.

DuPont™ Thru-Wall Flashing can be applied with an air and surface temperature of 32°F or higher.

For additional guidelines and suggested sealants, please call 1-800-44-Tyvek (800-448-9835), visit our website at www.construction.tyvek.com, or consult your local DuPont™ Tyvek® Specialist.

DuPont Flashing Systems Commercial Installation Guidelines

DUPONT™ THRU-WALL FLASHING INSTALLATION

Base of Wall With Outside Corner

- A. Apply a DuPont recommended primer. Following primer manufacturer's guidelines for appropriate coverage and drying times. Re-prime surface if primed area is left exposed >24 hours. (See page 3 General Instructions)
- B. Install preformed corners and end dams bedded in DuPont™ Commercial Sealant or recommended sealant in the appropriate locations along wall.
- C. Starting at a corner, remove the release sheet from the DuPont™ Thru-Wall Flashing, and apply membrane to primed surfaces in lengths of 8-10'.
- D. Extend the membrane completely through the wall and leave 1/4" minimum exposed to form a drip edge.
- E. Using a steel roller and firm hand pressure, roll the flashing into place to ensure continuous and direct contact with the substrate.
- F. End laps must be a minimum of 4" and overlap preformed corners a minimum of 4". Seal all laps with a manufacturer recommended sealant.
- G. (Optional) When using a metal drip plate, trim the exterior edge of the membrane 1" and secure per manufacturer's guidelines.
- H. Terminate the membrane on the vertical wall per plans and specifications. (Optional) Terminate into a reglet, counterflashing, or with a termination bar.
- I. DuPont™ Thru-Wall Flashing must be continuously supported by the substrate, must have no wrinkling, and must not span gaps or voids in excess of 1/2".
- J. Apply a sealant bead at each termination of the membrane with DuPont™ Commercial Sealant or recommended sealant.

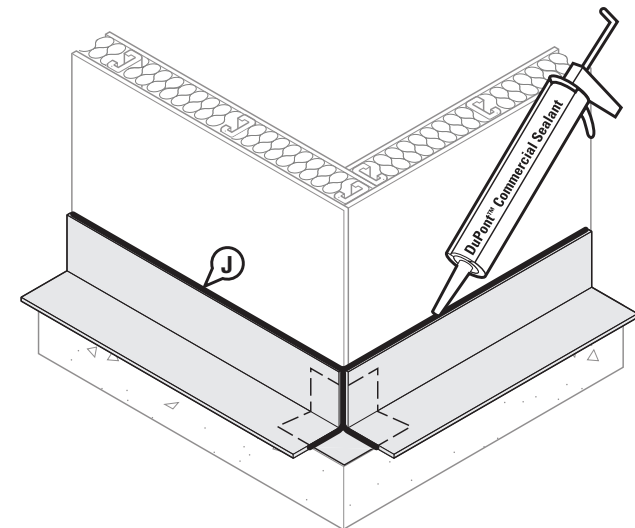
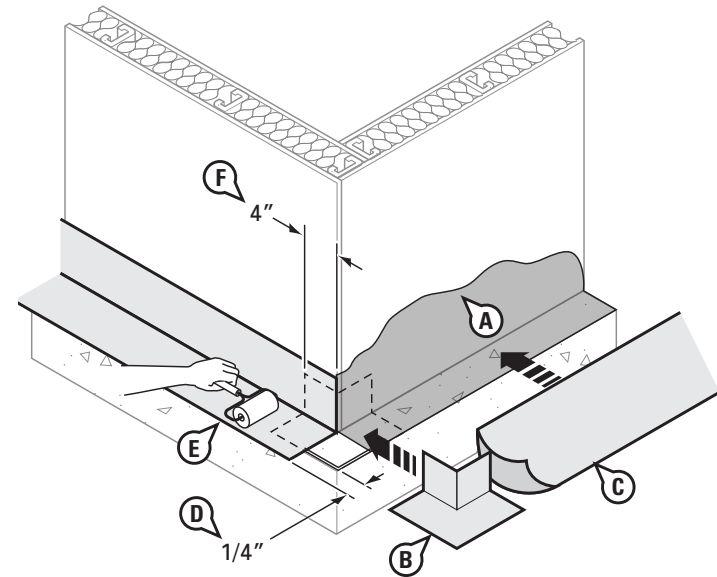

Technical Specifications

DuPont™ Tyvek® weather barriers used in construction products are made from 100% flash spunbonded high density polyethylene fibers which have been bonded together by heat and pressure, without binders or fillers, into a tough durable sheet structure. Additives have been incorporated into the polyethylene to provide ultraviolet light resistance. DuPont requires that DuPont™ Tyvek® CommercialWrap® and CommercialWrap® D be covered within nine months (270 days) of installation and DuPont™ Tyvek® ThermoWrap™ covered within four (4) months (120 days) of installation.

DuPont™ Thru-Wall Flashing is a 40 mil, self-adhesive composite flashing membrane. The top sheet is composed of DuPont™ Elvaloy® and thermoplastic ingredients that are reinforced with polyester fibers. A synthetic rubber adhesive is applied to the bottom surface of the membrane. A 1-1/2" edge of the top sheet does not have the synthetic rubber adhesive applied to it in order to provide a suitable surface for sealant adhesion and to use as a drip edge. Corners and end dams are made from DuPont™ Elvaloy® and thermoplastic ingredients. Additives have been incorporated to provide extended UV light resistance.

DuPont™ FlexWrap™ and StraightFlash™ flashing products are made from a synthetic rubber adhesive and a top sheet of flash spunbonded high density polyethylene fibers. Additives have been incorporated into these materials to help provide UV light resistance. DuPont requires that DuPont™ FlexWrap™ and DuPont™ be covered within four (4) months (120 days) of installation.

Warning

DuPont™ Tyvek® weather barriers are slippery and should not be used in any application where they will be walked on. In addition, because they are slippery, DuPont recommends using kickjacks, scaffolding, or lifts for exterior work above the first floor. If ladders must be used, extra caution must be taken to use them safely by following the requirements set forth in ANSI Standards 14.1, 14.2, and 14.5 for ladders made of wood, aluminum, and fiberglass, respectively. DuPont™ Tyvek® is combustible and should be protected from flames and other high heat sources. DuPont™ Tyvek® will melt at 275°F (135°C) and if the temperature of DuPont™ Tyvek® reaches 750°F (400°C), it will burn and the fire may spread and fall away from the point of ignition. For more information, call 1-800-44-Tyvek.

DuPont™ Thru-Wall Flashing, DuPont™ FlexWrap™, and DuPont™ StraightFlash™ products and their release paper are slippery and should not be walked on. Remove release paper from work area immediately. DuPont™ Thru-Wall Flashing will melt at temperatures greater than 480°F (250°C). DuPont™ FlexWrap™ and StraightFlash™ will melt at temperatures greater than 250°F (121°C). DuPont Flashing Systems products are combustible and should be protected from flame and other high heat sources. If burning occurs, ignited droplets may fall away from the point of ignition. For more information, call 1-800-44-Tyvek.

DuPont™ Weatherization Sealant is irritating to skin, eyes and respiratory tract. For proper usage, follow directions stated on the product label. For health information, refer to the Material Safety Data Sheet or call Chemtrec at 1-800-424-9300.

Note

When installed in conjunction with other building materials, DuPont Flashing Systems products must be properly shingled with these materials, such that water is diverted to the exterior of the wall system. DuPont™ Tyvek® products are secondary weather barriers, not the primary water barrier. The outer facade is the primary barrier. You must follow facade manufacturer's installation and maintenance requirements for all facade systems in order to maintain water holdout properties and ensure performance of DuPont™ Tyvek®. Use of additives, coatings or cleansers on or in the facade system may impact the performance of DuPont™ Tyvek® weather barriers. DuPont™ Tyvek® Weather Barrier Systems products are to be used as outlined in this installation guideline. For superior protection against bulk water penetration, DuPont suggests a system combining a quality exterior facade, a good secondary weather barrier and an exterior sheathing, appropriate flashing materials and details; and high quality windows and doors with particular attention to proper installation of each component. In a system where no exterior sheathing is used and DuPont™ Tyvek® is installed directly over the wall studs, exterior facade materials should be selected to ensure maximum protection against water intrusion. Careful workmanship and proper installation of each component is very important.

DuPont believes this information to be reliable and accurate. The information may be subject to revision as additional experience and knowledge is gained. It is the user's responsibility to determine the proper construction materials needed.

For complete warranty information please call 1-800-44-Tyvek.

To submit a warranty claim, please contact DuPont at www.construction.tyvek.com or call 1-800-44-Tyvek. Warranty coverage requires a submission of proof of purchase of the DuPont Weatherization Systems product(s) at issue.

This information is not intended to be used by others for advertising, promotion, or other publication for commercial purposes.

For more information about DuPont Weatherization Systems, please call 1-800-44-Tyvek or visit us at www.Construction.Tyvek.com



Tyvek®