



DuPont™
Tyvek®
CommercialWrap®

DuPont™
Tyvek®
Wrap Caps

DuPont™
Tyvek®
ThermaWrap™

DuPont™
Tyvek®
CommercialWrap® D

DuPont™
Tyvek®
Tape

DuPont™ Tyvek® Weather Barrier Commercial Installation Guidelines

METHODS FOR SUPERIOR PROTECTION AGAINST AIR AND WATER INTRUSION



Tyvek®

VERSION 4

DuPont™ Tyvek® Weather Barrier Commercial Installation Guidelines

Table of Contents

Applicable Products	2
Necessary Materials	2
Weather Barrier Code Requirements	3
Special Considerations	3
Installation Instructions.....	4
Continuity	5
Terminations	5
Penetrations.....	9
Recommended Fasteners and Spacing.....	10
Alternate Fastening	11
Handling Tears and Holes	12
Facade Considerations	12
Brick.....	12
EIFS	12
Stucco.....	13
Metal Panel.....	13
Stone Veneer	13
Wood Siding	13
Fiber Cement Siding	13
Key Installation Requirements for Wraps under the Product and Labor Warranty.....	14

Applicable Products

Weather Barriers

PRODUCT	DIMENSIONS	AREA
DuPont™ Tyvek® CommercialWrap®	5 ft x 200 ft 10 ft x 125 ft	1,000 sq ft 1,250 sq ft
DuPont™ Tyvek® CommercialWrap® D	5 ft x 200 ft 10 ft x 125 ft	1,000 sq ft 1,250 sq ft
DuPont™ Tyvek® ThermaWrap™	5 ft x 150 ft 9 ft x 105 ft	750 sq ft 900 sq ft

Installation Accessories

PRODUCT	TYPE	QUANTITY
DuPont™ Tyvek® Tape	3" Bulk Pack	24 Rolls/Case
DuPont™ Tyvek® Metallized Tape	2" x 100' Rolls	12 Rolls/Case
DuPont™ Tyvek® Wrap Caps	2" Wrap Cap Screw	1,000 Caps/Box

Flashing Products

PRODUCT	DIMENSIONS	AREA
DuPont™ FlexWrap™	7 in x 75 ft 9 in x 75 ft	43.7 sq ft 56.2 sq ft
DuPont™ FlexWrap™ NF	6 in x 75 ft 9 in x 75 ft	37.50 sq ft 56.20 sq ft
DuPont™ StraightFlash™	4 in x 150 ft 9 in x 125 ft	50 sq ft 93.75 sq ft
DuPont™ StraightFlash™ VF	6 in x 125 ft	62.5 sq ft
DuPont™ Thru-Wall Flashing	12 in x 75 ft 18 in x 75 ft 24 in x 75 ft 36 in x 75 ft	75 sq ft 112.5 sq ft 150 sq ft 225 sq ft

Warranty

Please refer to the DuPont Weatherization Products 10-Year Limited Warranty for Multi-Family, Mixed Use and Light Commercial Buildings Under Five Stories, for buildings less than 5 stories. For buildings greater than 5 stories, please refer to the DuPont Weatherization Products 10-Year Limited Warranty for Multi-Family, Mixed Use and Light Commercial Buildings Over Four Stories.

Necessary Materials

- DuPont™ Tyvek® Weather Barrier
- DuPont™ Tyvek® 3" Tape
- DuPont™ Commercial Sealant or DuPont recommended sealant
- DuPont™ Tyvek® Wrap Caps or recommended fasteners
- DuPont Flashing

Weather Barrier & Energy Conservation Codes and Standards

The 2009 International Building Code (Section 1403.2 Weather Protection) requires that exterior walls shall provide the building with a weather resistant exterior wall envelope. The exterior wall envelope shall include flashing, as described in Section 1405.3. DuPont™ Tyvek® Weatherization System products have been tested to the following standards.

- ASTM E 331 Standard Test Method for Water Penetration of Exterior Windows, Skylights, Doors, and Curtain Walls by Uniform Static Pressure
- ASTM E 2178 Standard Test Method for Air Permeance of Building Materials
- ASTM E 2357 Standard Test Method for Determining Air Leakage of Air Barrier Assemblies
- ASTM E 283 Standard Test Method for Determining Rate of Air Leakage Through Exterior Windows, Curtain Walls and Doors Under Specified Pressure Differences Across the Specimen.
- ASTM E 2556 Standard Specification for Vapor permeable Flexible sheet Water-resistive Barriers intended for mechanical attachment.

Energy Conservation Codes for commercial buildings are being adopted in many regions across the U.S. DuPont™ Tyvek® Fluid Applied Weather Barrier System products meet the following codes and guidelines.

- Proposed ASHRAE 90.1 Model Energy Code air barrier requirements
- Minnesota Commercial Energy Code, Section 1323.0543, Section 5.4.3
- Massachusetts State Building Code 780 CMR 120.AA
- Wisconsin Building Code, Energy Conservation, Chapter Comm 63
- Michigan Building Code
- Rhode Island Building Code
- Georgia Building Code
- Florida Building Code

The DuPont™ Tyvek® mechanically-attached weather barriers meet the ICC-ES AC-308 Water-Resistive and Air-Barrier requirements as listed in the following code reports:

ICC-ES Evaluation Report ESR-2375
DuPont™ Tyvek® DrainWrap™
DuPont™ Tyvek® CommercialWrap®
DuPont™ Tyvek® CommercialWrap® D

ICC-ES Evaluation Report ESR-1993:
DuPont™ Tyvek® ThermaWrap™

Special Considerations

1. DuPont™ Tyvek® CommercialWrap® D shall be installed with vertical grooves, going up and down.
2. DuPont requires that DuPont™ Tyvek® CommercialWrap® and DuPont™ Tyvek® CommercialWrap® D be covered within nine (9) months (270 days) of its installation. DuPont™ Tyvek® ThermaWrap™ must be covered within four (4) months (120 days) of its installation.
3. No surface preparation is needed for the installation of DuPont™ Tyvek® weather barriers.
4. Priming is generally not required for adhering DuPont Flashing Systems products to most common building materials. However, adverse weather conditions or cold temperatures may require use of a primer to promote adhesion. Additionally, concrete, masonry, and fiber faced exterior gypsum board require the use of recommended primers. Consult your local DuPont™ Tyvek® Specialist for primer recommendations and recommended primers.

DuPont Flashing Systems products perform best when installed at temperatures above 25°F (-4°C).
5. To claim the effective R-Value benefits of DuPont™ Tyvek® ThermaWrap™ it shall be installed with shiny, metallic side facing towards a clear ¾ inch minimum airspace. Without an airspace, the effective R-value of DuPont™ Tyvek® ThermaWrap™ will be reduced or eliminated but DuPont™ Tyvek® ThermaWrap™ will still act as a weather barrier.
6. Before applying 3" DuPont™ Tyvek® Tape, surfaces should be dry and clean. During installation firm even pressure should be used with the hand or "J" roller.
7. DuPont™ FlexWrap™ NF can be used in place of DuPont™ FlexWrap™ throughout this guide.
8. DuPont™ Commercial Sealant should be tooled flat to allow the natural curing process to create a concave joint.
9. DuPont™ Corners and DuPont™ End Dams are recommended as a best practice to be used with DuPont™ Thru-Wall Flashing. Alternatives can be used if it meets the design intent of the building.
10. When high performance installations are required, DuPont™ StraightFlash™ or DuPont recommended alternate shall be used at terminations and as patches behind fastening plates (brick tie base plates, metal fastening clips, metal channels, etc.)

For additional guidelines and suggested recommended sealants, please call 1-800-44-Tyvek (800-448-9835), visit our website at www.Weatherization.Tyvek.com, or consult your local DuPont™ Tyvek® Specialist.

Installation Instructions

STEP 1

- A. Starting at a corner of the building unroll DuPont™ Tyvek® weather barrier keeping the roll plumb. Extend approximately 12" past either the inside or outside corner of the wall.
- B. Vertically overlap the next sheet of DuPont™ Tyvek® by at least 6". Vertical grid lines have been provided every 8" on DuPont™ Tyvek® CommercialWrap® to assist in alignment with stud spacing.

Note: It is important that proper shingling is maintained. DuPont™ Tyvek® weather barriers should be installed from the bottom of the building up to ensure proper shingling.

Note: Vertical installation of DuPont™ Tyvek® CommercialWrap® and DuPont™ Tyvek® ThermaWrap™ is acceptable. 6" overlap and proper shingling of vertical and horizontal seams is required. This installation is not permitted for DuPont™ Tyvek® CommercialWrap® D.

STEP 2

DuPont™ Tyvek® should overlap through-wall flashing* by a minimum of 6". For maximum air leakage reduction (when installing as an air barrier), seal wrap at the bottom of the wall with sealant, DuPont™ Tyvek® Tape, or DuPont™ StraightFlash™. (If no through-wall flashing* is being used, the bottom edge of DuPont™ Tyvek® should extend over the sill plate by at least 2".)

Note: Refer to DuPont™ Thru-Wall Flashing installation guidelines located on the web site or located in the Flashing Guide to properly integrate DuPont™ Tyvek® weather barriers with the through-wall flashing.*

STEP 3

Secure DuPont™ Tyvek® weather barrier by fastening into the studs. For fastener type and spacing refer to the "Recommended Fasteners and Spacing" section of this document.

Note: In order to keep DuPont™ Tyvek® from being damaged by cladding installation, special attention should be taken to ensure that the DuPont™ Tyvek® is pressed tightly into any inside corners before fastening.

STEP 4

Unroll DuPont™ Tyvek® directly over windows and doors rough openings. Upper layer of DuPont™ Tyvek® should overlap bottom layer of DuPont™ Tyvek® by a minimum of 6". Do not install fasteners within 6" of the sills and jambs of the openings and within 9" of the head of the openings.

DuPont™ Tyvek® will be fastened during flashing installation. Refer to the Commercial DuPont Flashing Systems Installation Guidelines to prepare window and door openings.

STEP 5

Tape all horizontal and vertical seams with 3" DuPont™ Tyvek® Tape.

STEP 6

After weather barrier is installed, refer to the Commercial DuPont Flashing Systems Installation Guidelines to prepare and flash windows and doors.

Note: When installing second layer of weather barrier over DuPont™ Tyvek® use DuPont recommended fastening schedule using temporary or permanent fasteners.

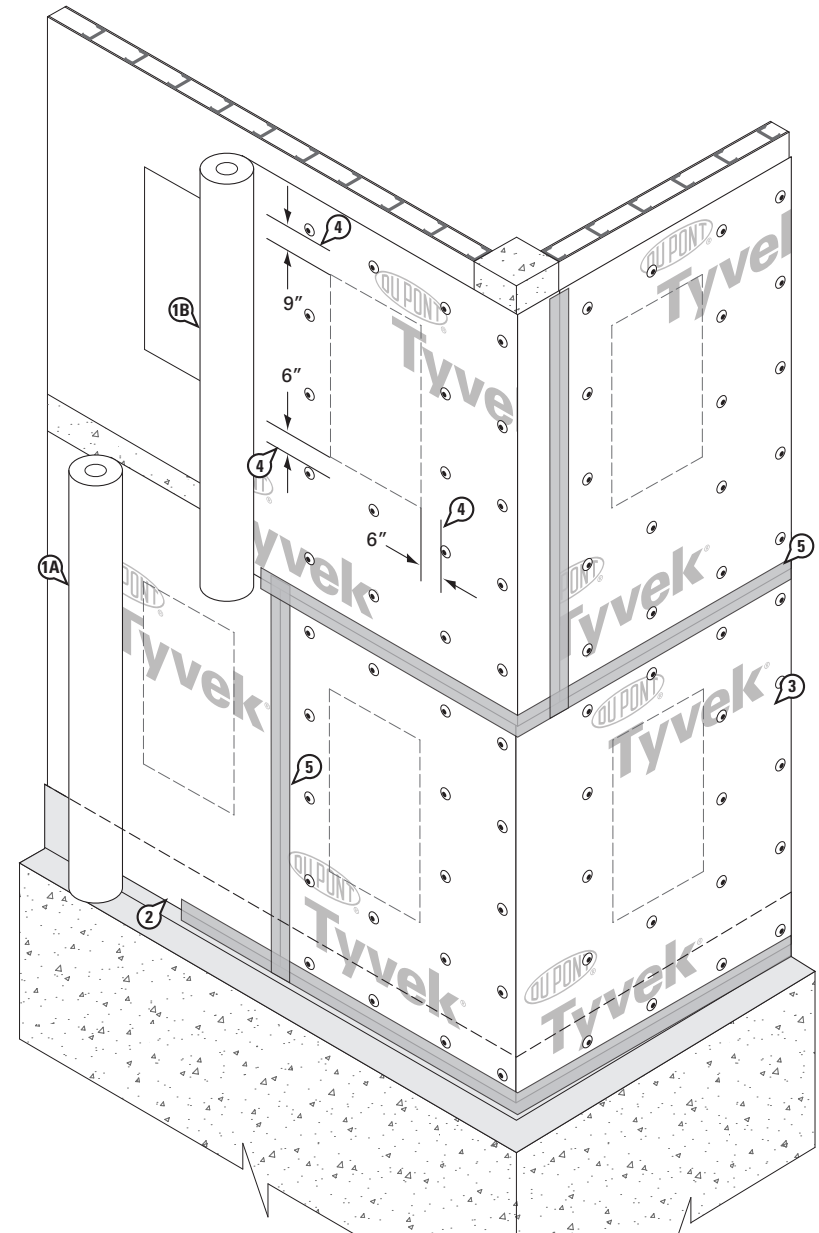

*DuPont™ Thru-Wall Flashing recommended.

Continuity

Terminations

It is important to maintain the continuity of the weather barrier from top to bottom with proper shingling. The entire wall surface shall be wrapped, including unconditioned spaces.

Special attention should be given to all terminations and transitions to ensure a proper drainage plane and a continuous weather barrier is maintained.

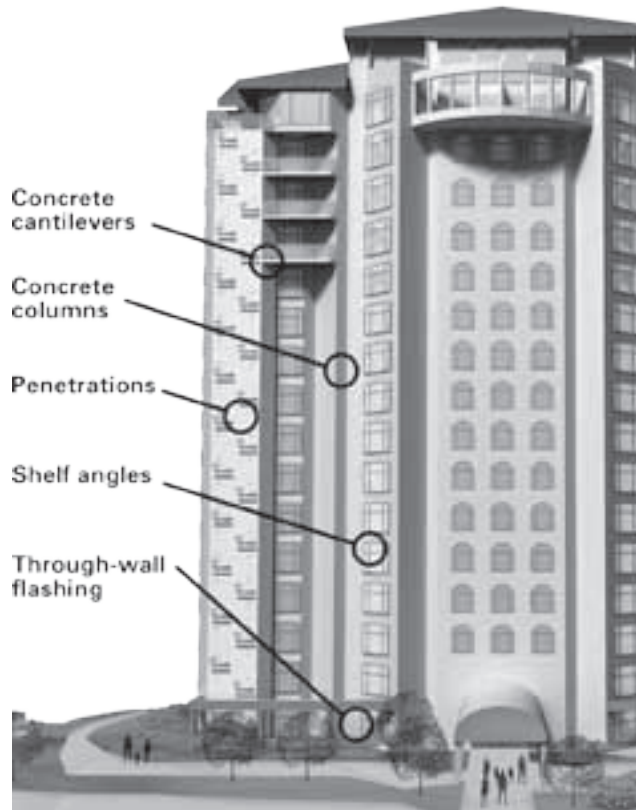

Through-Wall Flashing*

- A. Overlap through-wall flashing* by 6".
- B. Mechanically fasten bottom of weather barrier through top of through-wall flashing*.
- C. Seal vertical and horizontal seams using 3" DuPont™ Tyvek® Tape or DuPont™ StraightFlash™.

*DuPont™ Thru-Wall Flashing recommended.

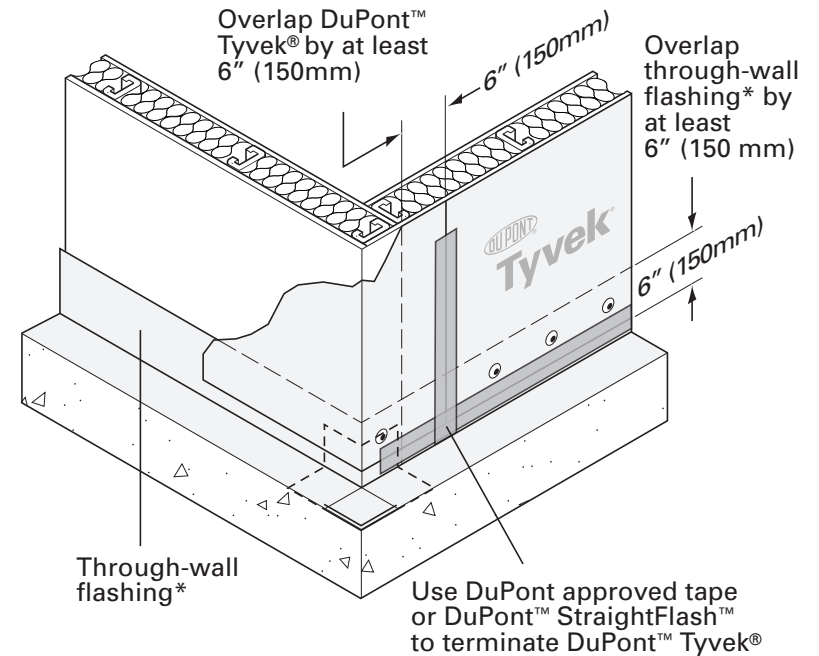

DuPont™ Tyvek® Weather Barrier Commercial Installation Guidelines

Shelf Angles

- A. Through-wall flashing* should be applied to the top of the shelf angle and the DuPont™ Tyvek® weather barrier should be properly shingled over by at least 6”.
- B. Seal the DuPont™ Tyvek® weather barrier to the bottom of the shelf angle using DuPont Flashing.
- C. Seal bottom of the DuPont™ Tyvek® weather barrier to through-wall flashing* using 3” DuPont™ Tyvek® Tape or DuPont™ StraightFlash™.

*DuPont™ Thru-Wall Flashing recommended.

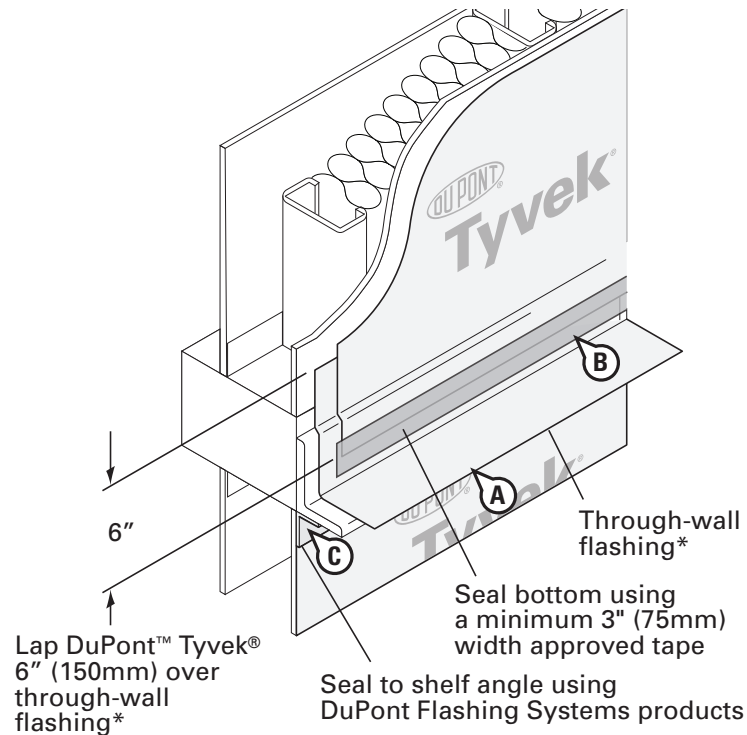

Concrete Cantilevers

Seal to concrete cantilevers using DuPont recommended primer and DuPont Flashing Systems products.

STEP 1

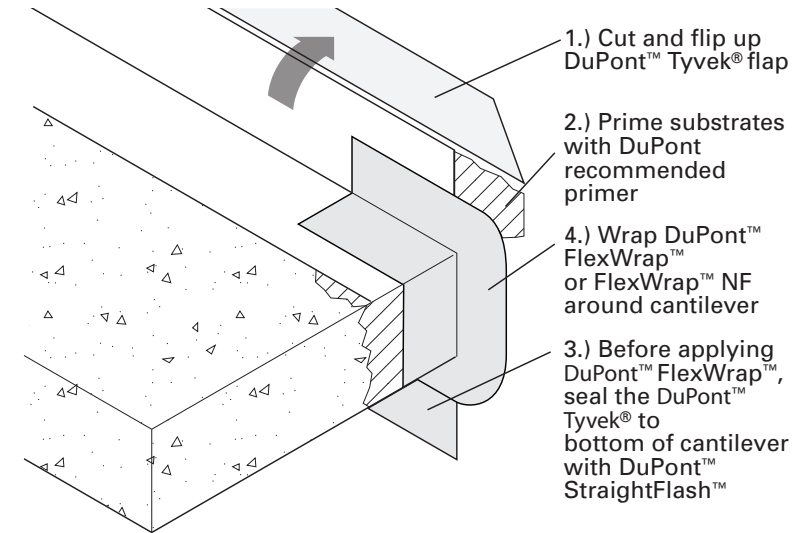

STEP 2

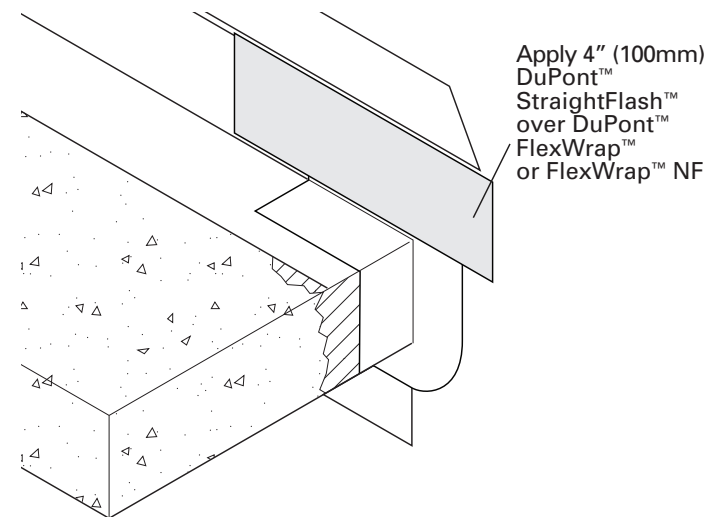

DuPont™ Tyvek® Weather Barrier Commercial Installation Guidelines

STEP 3

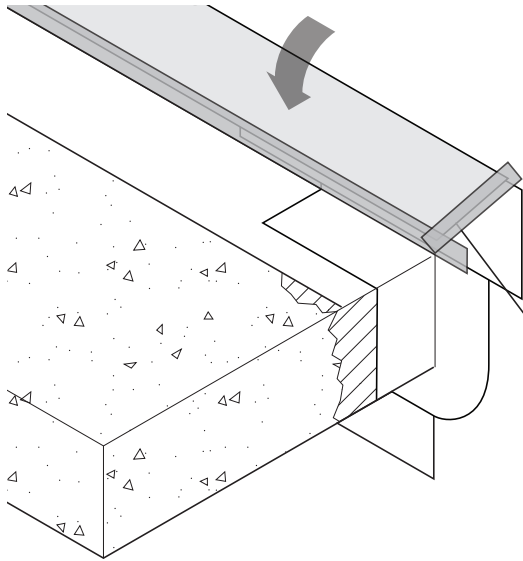

Flip DuPont™ Tyvek® down and tape seams using a minimum 3" (75mm) width approved tape

Concrete Column (Method 1)

- Wrap DuPont™ Tyvek® weather barrier around concrete column.
- Mechanically fasten DuPont™ Tyvek® weather barrier at recommend spacing. (See recommended fasteners and spacing section of this document)

Note

Mechanically fasten DuPont™ Tyvek® weather barrier to concrete column if necessary to maintain recommended fastener spacing.

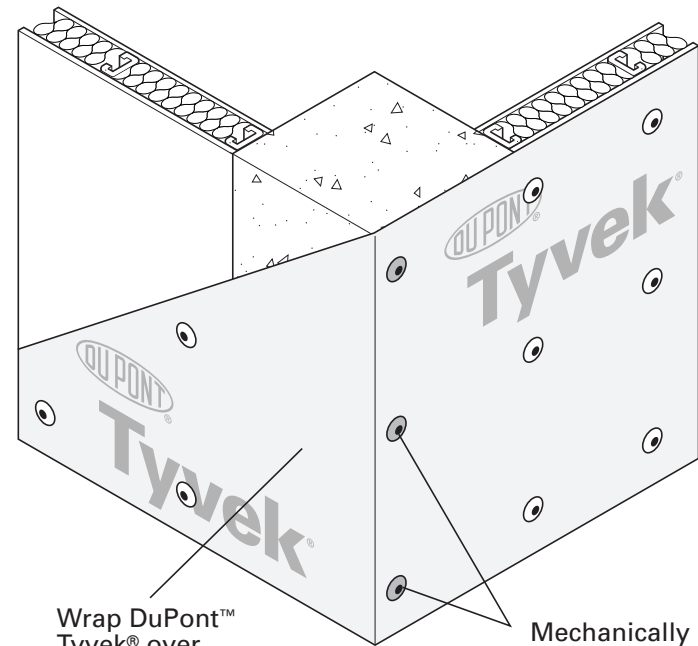

Wrap DuPont™ Tyvek® over concrete column

Mechanically fasten DuPont™ Tyvek® at recommended spacing
Use appropriate fastener for each substrate

DuPont™ Tyvek® Weather Barrier Commercial Installation Guidelines

Concrete Column (Method 2)

- A. Prime concrete column with DuPont recommended primer.
- B. Cut DuPont™ Tyvek® weather barrier at concrete column, leaving approximately 2" overlapping column.
- C. Mechanically fasten weather barrier into studs.
- D. Seal weather barrier to concrete using DuPont Flashing Systems products.

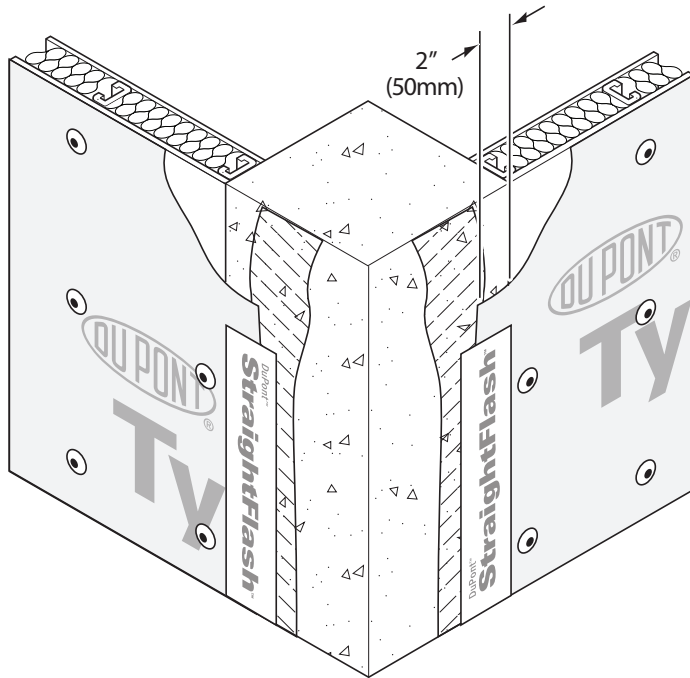

Option 1

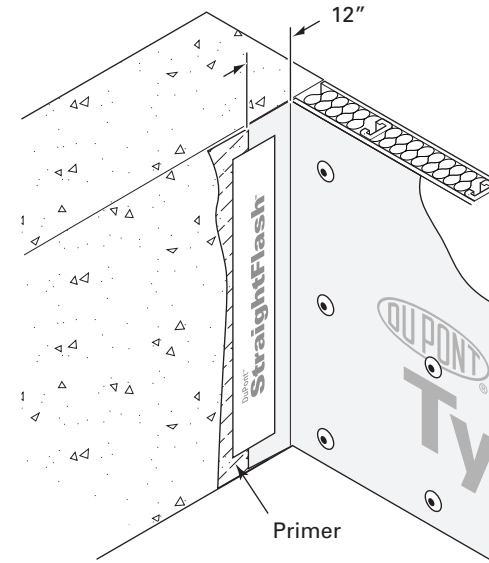

Option 2

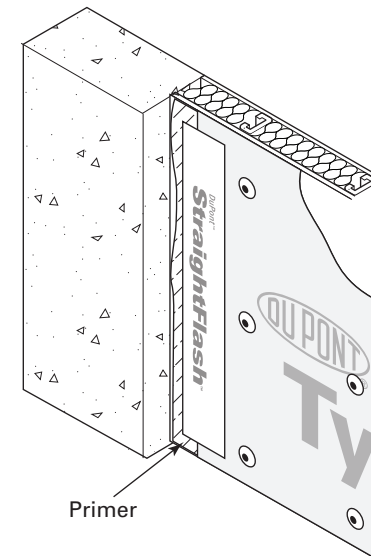

DuPont™ Tyvek® Weather Barrier Commercial Installation Guidelines

Penetrations

Seal the DuPont™ Tyvek® around all electrical, HVAC and plumbing penetrations with sealant and DuPont™ Tyvek® Tape, DuPont™ FlexWrap™ or DuPont™ FlexWrap™ NF. When using DuPont™ FlexWrap™ NF fasteners are not required. Products that have flanges should be integrated into the weather barrier using DuPont™ Tyvek® Tape or DuPont Flashing Systems products. DuPont™ StraightFlash™ or DuPont recommended alternate patches should be applied behind brick tie base plates and other metal fastening plates.

DuPont™ Tyvek® Tape should first be applied around penetration. DuPont™ Tyvek® Tape is used to reinforce the DuPont™ Tyvek® weather barrier. It is important that the tape be tightly installed to the penetrating object. Next apply an adequate amount of DuPont™ Commercial Sealant or DuPont recommended sealant around the penetration.

STEP 1

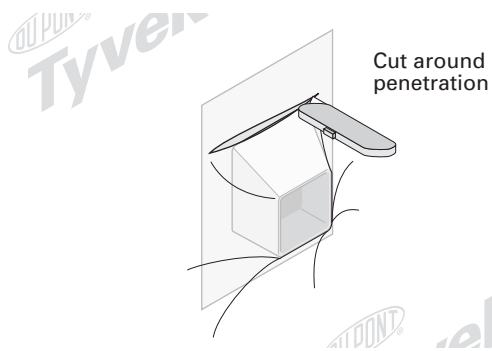

STEP 2

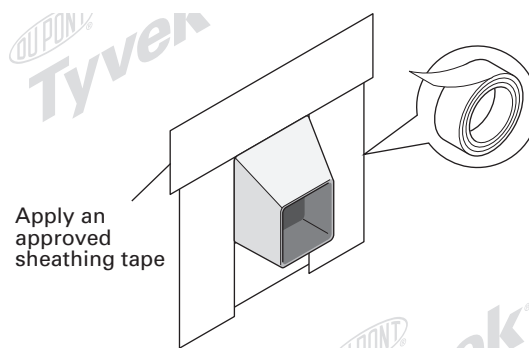

STEP 3

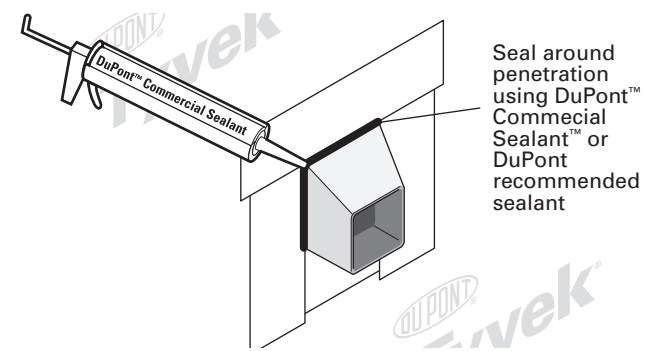

STEP 1

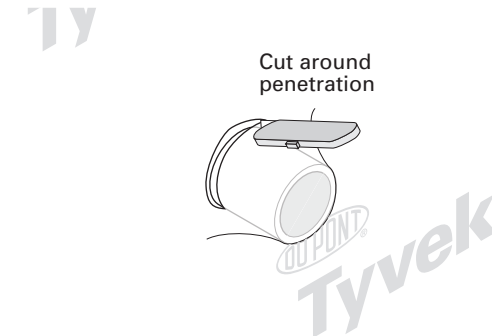

STEP 2

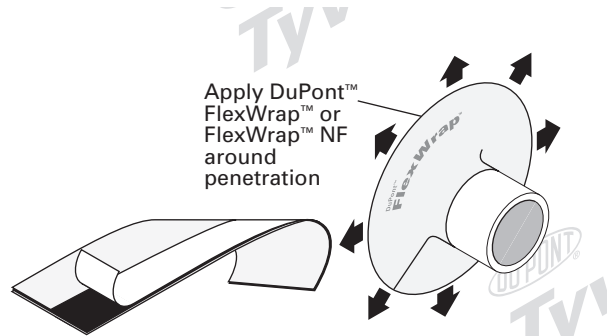

STEP 3

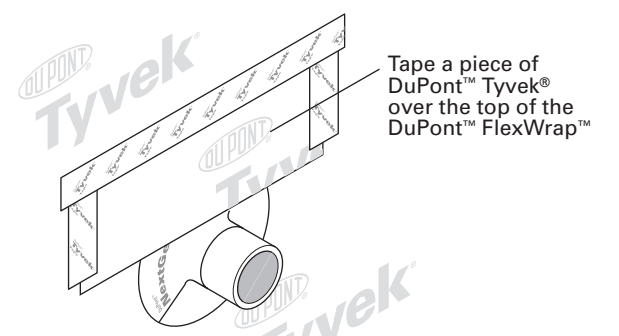

Recommended Fasteners and Spacing

- DuPont 2" plastic cap screws
- 1-1/4" metal gasketed washers with screws
- 2" metal gasketed washers with screws
- 1" plastic cap staple with leg length sufficient to achieve 5/8" penetration into wood stud (for wood frame construction)
- #4 nails with 1" plastic cap (for wood frame construction)
- Tapcon® fasteners with 2" plastic caps (for masonry construction)

Table 1 – DuPont™ Tyvek® Weather Barrier with Screw Fasteners and 16" O.C. Steel Stud Spacing

Washer Size	Fastener Spacing	Allowable Pressure*	
		psf	mph
2" Metal	12"	90 psf	188 mph
	18"	60 psf	153 mph
2" Plastic	12"	70 psf	165 mph
	18"	45 psf	133 mph
1.25" Metal	12"	60 psf	153 mph
	18"	40 psf	125 mph

*Values presented are maximum allowable pressures. A factor of safety may need to be applied for certain cladding systems.

Temporary Fastening

Selection and use of temporary fastening methods is an option dependent on building schedule, cladding options, and local building practices. Temporary fasteners should not be relied upon to permanently attach DuPont™ Tyvek® weather barriers, due to the limited holding power of these fastening methods. If temporary fasteners are used, permanent fastening should be applied as soon as practically possible in order to maintain the integrity and performance of the DuPont™ Tyvek® weather barrier.

Temporary fastening methods:

- DuPont recommended fasteners at a reduced schedule 24-48".
- DuPont recommended adhesives applied in vertical strips at 24-36" spacing or along every other stud line.
- 1-inch cap staple in wood-based sheathing and behind 3-coat stucco, foam, or stone veneer applications.
- Smaller staples (slap staples) in wood-based sheathing (OSB, plywood) with a fastener schedule that does not exceed 4 per square yard. Small staple fasteners should not be used in fiberboard or foam sheathing.
- If small staples are used to temporarily fasten DuPont™ Tyvek® weather barriers to exterior gypsum, the fastening schedule must not exceed 4 per square yard and each staple must be covered with DuPont™ Tyvek® Tape. Covering the staples underneath a taped weather barrier seam is acceptable.

Alternate Fastening

- A. Standard brick tie base plates and metal plates with DuPont™ StraightFlash™ or DuPont recommended alternate patches behind.
- B. Metal channels, horizontal z-girts, etc. with DuPont™ StraightFlash™ or DuPont recommended alternate behind when high performance installations are required.
- C. Wood furring strips mounted vertically.
DuPont™ StraightFlash™ or DuPont recommended alternate not required unless the furring strips are shimmed.

Note

- Additional fasteners may be needed between brick ties, and other alternate fasteners to maintain recommended fastener spacing.

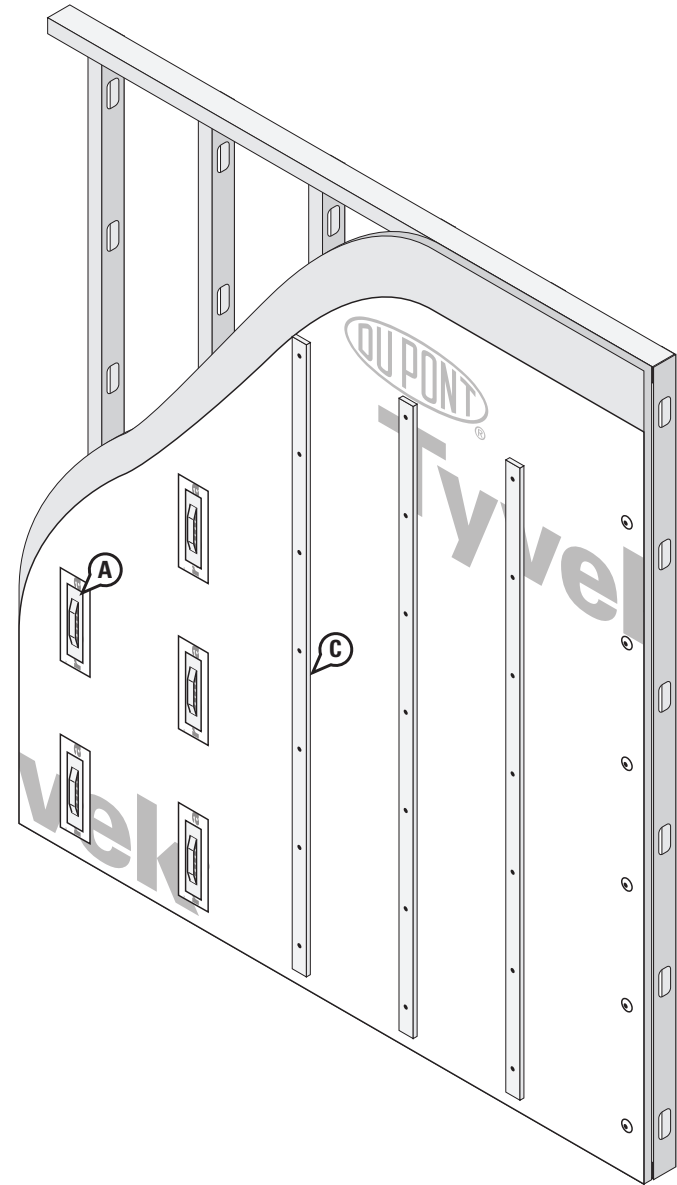

Handling Tears and Holes

- During the course of installing the DuPont™ Tyvek® weather barrier, minor tears may occur. Be sure to tape all tears. Tears can easily be covered with 3" DuPont™ Tyvek® Tape or DuPont Flashing Systems products.
- Larger tears may require you to cut a piece of DuPont™ Tyvek® to repair the tear. Measure and cut a piece of DuPont™ Tyvek® large enough to cover tear by 6". Cut above the top of the tear large enough to accommodate the patch. Tuck patch into slit at least 6" and shingle over lower weather barrier. Tape along the perimeter by starting at bottom of tear and shingling the upper tape over the bottom tape.

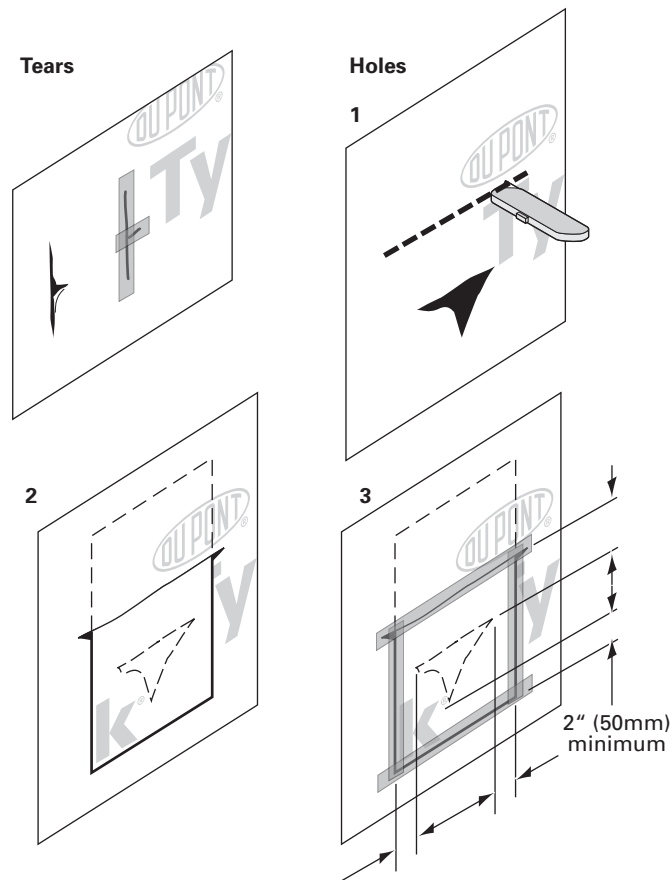

Facade/Exterior Considerations

Brick

The Brick Industry Association recommends a 1" air-space in front of wood stud construction and a 2" air-space in front of steel stud construction. Consistent with these requirements and recommendations, DuPont™ Tyvek® weather barriers shall be separated from the brick veneer by a minimum 1" air-space. Window and door flashing, and through-wall flashing* shall be integrated with the DuPont™ Tyvek® layer ensuring proper shingling. For maximum moisture management and drying of the wall system the airspace in front of the DuPont™ Tyvek® shall be vented to the exterior at the top and bottom of the wall. Some types of brick ties can act as alternate fasteners for the weather barriers. Installing alternate fasteners within 24 hours of the DuPont™ Tyvek® layer may reduce the required number of fasteners used for the initial attachment of the DuPont™ Tyvek® weather barrier.

EIFS

DuPont™ Tyvek® weather barriers and EIFS cladding shall be installed according to manufacturer's instructions and industry standards. In order to promote drainage, it is recommended that DuPont™ Tyvek® CommercialWrap® D be installed behind the exterior insulation. Window and door flashing, and through-wall flashing* shall be integrated with the DuPont™ Tyvek® layer ensuring proper shingling. The successful installation and performance of EIFS cladding is dependent upon the proper design and construction of the adjacent materials and systems of the structure.

Exterior Insulation

DuPont™ Tyvek® weather barriers and exterior insulation shall be installed according to the manufacturer's instructions and industry standards. DuPont™ Tyvek® weather barriers can be installed either over the rigid exterior insulation or underneath between the sheathing and the exterior insulation. In order to promote drainage, it is recommended that DuPont™ Tyvek® CommercialWrap® D be used when installing the DuPont™ Tyvek® layer between the sheathing and exterior insulation. Window flashing, door flashing, and through-wall flashing shall be integrated with the DuPont™ Tyvek® layer ensuring proper shingling. The successful installation and performance of exterior insulation is dependent upon the proper design and construction of adjacent materials and systems of the structure.

*DuPont™ Thru-Wall Flashing recommended.

DuPont™ Tyvek® Weather Barrier Commercial Installation Guidelines

Stucco

When stucco is installed over wood-based sheathing the 2009 International Building Code (Section 2510.6) requires “a weather-resistive barrier with a performance at least equivalent to two layers of Grade D paper” or a layer of weather barrier which is separated from the stucco by an “intervening layer”. When DuPont™ Tyvek® weather barriers are used behind stucco they should be separated from the stucco by a second layer of DuPont™ Tyvek® weather barrier, a layer of Grade D building paper, felt, rigid foam board or the paper backing of paper-backed lath. The first layer (directly over sheathing or studs) serves as the wall system’s weather barrier and is integrated with window and door flashings, the weep screed at the bottom of the wall and any through-wall flashings* or expansion joints. Lath shall be installed over the intervening layer (second layer) in accordance with ASTM C1063-03 Standard Specification for Installation of Lathing and Furring to Receive Interior and Exterior Portland Cement-Based Plaster and applicable codes. Rigid foam board, when installed over DuPont™ Tyvek® weather barrier as an intervening layer, may provide enhanced structural support to the DuPont™ Tyvek® layer and alternate fasteners for the weather barriers. Installing alternate fasteners within 24 hours of the DuPont™ Tyvek® layer may reduce the required number of fasteners used for the initial attachment of the DuPont™ Tyvek® weather barrier.

Metal Panel

DuPont™ Tyvek® weather barriers and metal panel cladding systems shall be installed according to manufacturer’s instructions and industry standards. It is recommended that DuPont™ StraightFlash™ or DuPont recommended alternate patches be installed behind all metal installation brackets. Window and door flashing, and through-wall flashing* shall be integrated with the DuPont™ Tyvek® layer ensuring proper shingling.

Stone Veneer

The 2009 International Building Code (Section 1405.6) requires two layers of weather barrier behind stone veneers over wood frame construction. When used behind stone veneer, DuPont™ Tyvek® weather barriers shall be installed in a similar manner as they are installed behind stucco. DuPont™ Tyvek® weather barriers should be separated from the stone and mortar by a second layer of DuPont™ Tyvek® weather barrier, a layer of grade D building paper, felt, rigid foam board or the paper backing of paper-backed lath. The first layer (directly over sheathing or studs) serves as the wall system’s weather barrier and shall be integrated with window and door flashings, the weep screed at the bottom of the wall and any through-wall flashings* or expansion joints.

Wood Siding

DuPont™ Tyvek® weather barriers and wood siding shall be installed according to manufacturer’s instructions, industry standards and applicable codes. As recommended by the Western Red Cedar Lumber Association and U. S. Forest Product Laboratory, wood siding should be primed on all six sides before installation. In high exposure installations, enhanced drainage and water management may be provided by using DuPont™ Tyvek® CommercialWrap® D or by creating rainscreen cladding with a larger airspace behind the siding using furring strips.

Fiber Cement Siding

DuPont™ Tyvek® weather barriers and fiber cement siding shall be installed according to manufacturer’s instructions and industry standards. In high exposure installations, enhanced drainage and water management may be provided by using DuPont™ Tyvek® CommercialWrap® D or by creating rainscreen cladding with a larger airspace behind the siding using furring strips.

*DuPont™ Thru-Wall Flashing recommended.

Key Installation Requirements for Wraps under the Product and Labor Warranty

Continuity

It is important to maintain the continuity of the weather barrier throughout the building envelope. The entire wall surface shall be wrapped, including unconditioned spaces. Special attention should be given to ensure a proper 6" overlap at all terminations, seams, penetrations, and transitions to maintain a continuous downward drainage plane and weather barrier. Installing the DuPont™ Tyvek® weather barrier as an air barrier is the preferred installation method, but when the DuPont™ Tyvek® weather barrier is being installed as a water-resistive barrier only (residential / low-rise), then skip-taping terminations and untaped horizontal seams are allowed. All vertical seams must be taped for both air barrier and water-resistive barrier installations.

Penetrations

Seal the DuPont™ Tyvek® around all penetrations (electrical, HVAC and plumbing, etc.) with the appropriate DuPont Flashing Systems product, DuPont™ Tyvek® Tape, or recommended sealant. Products that have flanges should be integrated into the weather barrier. DuPont™ StraightFlash™ or DuPont recommended alternate patches should be applied behind fastening plates (brick tie base plates, metal fastening clips, metal channels, etc.) when building envelope design requirements exceed ASTM E1677, 65 mph equivalent structural load and 15 mph equivalent wind-driven rain water infiltration resistance. Please contact 1-800-44-Tyvek for recommended sealants and recommended alternate patches behind fastening plates.

Overlap

Ensure proper shingling with a 6" minimum overlap of weather barrier components from the bottom to the top of the wall to help facilitate proper drainage.

Fasteners

Use DuPont fasteners or DuPont recommended alternates per the fastening schedule included in this installation guideline. Temporary fasteners should not be relied upon to permanently attach DuPont™ Tyvek® weather barriers, due to the limited holding power of these fastening methods and will not be in compliance with DuPont Installation Guidelines if making a claim under the DuPont Product and Labor Warranty. If temporary fasteners are used, permanent fastening must be applied as soon as practically possible in order to maintain the integrity and performance of the DuPont™ Tyvek® weather barrier. Refer to the DuPont™ Tyvek® Weather Barrier Commercial Guidelines page 10 for more complete fastening information. Examples of recommended permanent fasteners include:

RECOMMENDED FASTENERS

- DuPont™ Tyvek® Wrap Cap nails (for wood frame construction)
- DuPont™ Tyvek® Wrap Cap Staples for Stinger™ (for wood frame construction)
- 1.0 inch minimum crown staples for residential/low rise construction (except when installing DuPont™ Tyvek® over foam sheathing)
- 1" plastic cap staple with leg length sufficient to achieve 5/8" penetration into wood stud (for wood frame construction)
- DuPont™ Tyvek® Wrap Cap 2" plastic cap screws (for steel or wood frame construction)
- 1-1/4" metal gasketed washers with screws (for steel frame construction)
- 2" metal gasketed washers with screws (for steel frame construction)
- Tapcon® fasteners with 2" plastic caps (for masonry construction)

Special Considerations

Refer to DuPont™ Tyvek® Installation Guidelines for special considerations such as UV exposure, compatibility with other materials, surface burning characteristics, etc.

PROPER OVERLAP FOR WATER MANAGEMENT

- A. Lap all components from bottom of the wall to the top of the wall
- B. Treat the walls of the building just like a roof

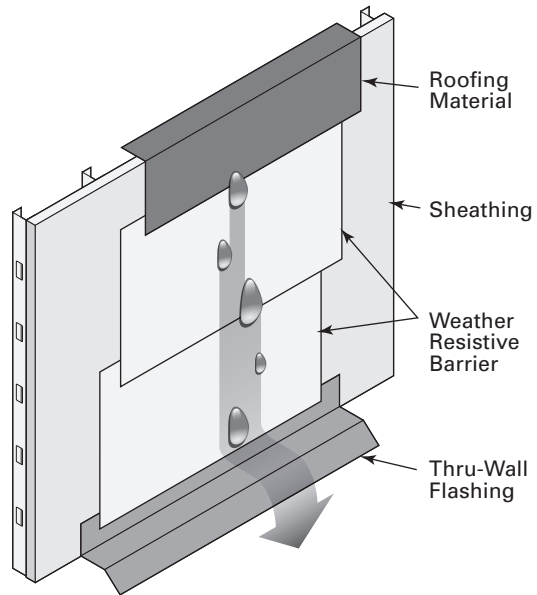

Note: In order to make a claim under the DuPont 10 Year Product and Labor Warranty on DuPont Weatherization Products, you must have met all of the terms and conditions of the warranty, including use of the applicable DuPont Installation Guidelines (Commercial or Residential). In the event that a specific detail or installation technique is not covered in the DuPont Installation Guidelines at the time you are building, then the general principles outlined in this document must have been followed in order to make a claim under the warranty. Please contact DuPont or a DuPont Specialist if you have any questions in connection with any DuPont Installation Guideline.

Technical Specifications

DuPont™ Tyvek® weather barriers used in construction products are made from 100% flash spunbonded high density polyethylene fibers which have been bonded together by heat and pressure, without binders or fillers, into a tough durable sheet structure. Additives have been incorporated into the polyethylene to provide ultraviolet light resistance. DuPont requires that DuPont™ Tyvek® CommercialWrap® and CommercialWrap® D be covered within nine (9) months (270 days) of installation and DuPont™ Tyvek® ThermaWrap™ covered within four (4) months (120 days) of installation.

DuPont™ Thru-Wall Flashing is a 40 mil, self-adhesive composite flashing membrane. The top sheet is composed of DuPont™ Elvaloy® and thermoplastic ingredients that are reinforced with polyester fibers. A synthetic rubber adhesive is applied to the bottom surface of the membrane. A 1-1/2" edge of the top sheet does not have the synthetic rubber adhesive applied to it in order to provide a suitable surface for sealant adhesion and to use as a drip edge. Corners and end dams are made from DuPont™ Elvaloy® and thermoplastic ingredients. Additives have been incorporated to provide extended UV light resistance.

DuPont™ FlexWrap™ and StraightFlash™ flashing products are made from a synthetic rubber adhesive and a top sheet of flash spunbonded high density polyethylene fibers. Additives have been incorporated into these materials to help provide UV light resistance. DuPont requires that DuPont™ FlexWrap™ and StraightFlash™ be covered within (4) four months (120 days) of installation.

Warning

DuPont™ Tyvek® weather barriers are slippery and should not be used in any application where they will be walked on. In addition, because they are slippery, DuPont recommends using kickjacks, scaffolding, or lifts for exterior work above the first floor. If ladders must be used, extra caution must be taken to use them safely by following the requirements set forth in ANSI Standards 14.1, 14.2, and 14.5 for ladders made of wood, aluminum, and fiberglass, respectively. DuPont™ Tyvek® is combustible and should be protected from flames and other high heat sources. DuPont™ Tyvek® will melt at 275°F (135°C) and if the temperature of DuPont™ Tyvek® reaches 750°F (400°C), it will burn and the fire may spread and fall away from the point of ignition. For more information, call 1-800-44-Tyvek.

DuPont™ Thru-Wall Flashing, DuPont™ FlexWrap™, and DuPont™ StraightFlash™ products and their release paper are slippery and should not be walked on. Remove release paper from work area immediately. DuPont™ Thru-Wall Flashing will melt at temperatures greater than 480°F (250°C). DuPont™ FlexWrap™ and StraightFlash™ will melt at temperatures greater than 250°F (121°C). DuPont Flashing Systems products are combustible and should be protected from flames and other high heat sources. If burning occurs, ignited droplets may fall away from the point of ignition. For more information, call 1-800-44-Tyvek.

DuPont™ Commercial Sealant is irritating to skin, eyes and respiratory tract. For proper usage, follow directions stated on the product label. For health information, refer to the Material Safety Data Sheet or call Chemtrec at 1-800-424-9300.

Note

When installed in conjunction with other building materials, DuPont Flashing Systems products must be properly shingled with these materials such that water is diverted to the exterior of the wall system. DuPont™ Tyvek® products are WRBs and not the primary water barrier. The outer facade is the primary barrier. You must follow facade manufacturer's installation and maintenance requirements for all facade systems in order to maintain water holdout properties and ensure performance of DuPont™ Tyvek®. Use of additives, coatings or cleansers on or in the facade system may impact the performance of DuPont™ Tyvek® water-resistive barriers. DuPont™ Tyvek® Weatherization Systems products are to be used as outlined in this installation guideline. DuPont Flashing Systems products should only be used to seal penetrations and flash openings in houses or buildings. DuPont Flashing Systems products are not to be used in roofing applications. For superior protection against bulk water penetration, DuPont suggests a system combining a quality exterior facade, a good secondary weather barrier and exterior sheathing, high quality windows and doors, and appropriate flashing materials paying attention to proper installation of each component. In a system where no exterior sheathing is used and DuPont™ Tyvek® weather barrier is installed directly over the wall studs, exterior facade materials should be selected to ensure maximum protection against water intrusion. Careful workmanship and proper installation of each component is very important.

DuPont believes this information to be reliable and accurate. The information may be subject to revision as additional experience and knowledge is gained. It is the user's responsibility to determine the proper construction materials needed.

For complete warranty information please call 1-800-44-Tyvek.

This information is not intended to be used by others for advertising, promotion, or other publication for commercial purposes.

For more information about DuPont Weatherization Systems, please call 1-800-44-Tyvek or visit us at www.Weatherization.Tyvek.com



Tyvek.